

ULTRASONIC

Distance and Proximity Sensors



Series UN

Key-Features:

- Very flat profile, small size
- Measurement ranges 80 up to 5000 mm
- High detection sensitivity
- Versions with analog and/or binary output
- Versions with synchronisation input
- Linearity $\pm 0.5\%$
- Working temperature -20 up to +50 °C
- Measurement independent of material, surface, colour and size of target
- Protection class IP67, oil resistant
- M8 sensor connector or cable connection

Content:

Technical Data2
Description3
Technical Drawing5
Detection Beams5
Connection & Applications6
Order Code7
Options & Accessories7

TECHNICAL DATA

Type		UN500	UN1000	UN2500	UN5000
Measurement range nominal, with standard versions	[mm]	80...500	135...1000	250...2500	400...5000
Measurement range POR-version for bigger objects	[mm]	80...approx. 800	135...approx. 1500	250...approx. 3000	400...approx. 6500
Adjustment range of binary output (with potentiometer)	[mm]	80...500	135...1000	250...2500	400...5000
Hysteresis of binary output, axial	[mm]	approx. 15	approx. 25	approx. 40	approx. 80
Resolution	[%FS]	approx. 0.2	approx. 0.1	approx. 0.1	approx. 0.1
Linearity	[%FS]	<±0.5			
Temperature error -20...+50 °C	[%]	<1			
Over all accuracy in whole temperature range	[%FS]	approx. ±1			
Operating frequency	[kHz]	approx. 180	approx. 180	approx. 120	approx. 80
Status indicator		LED red/green			
Binary output, short circuit proof, max. 0.1 A		by choice PNP, NPN, closer, opener			
Switching speed max.	[Hz]	approx. 8	approx. 5	approx. 3	approx. 2
t _{on} / t _{off} binary output (50 % FS, without background)	[ms]	approx. 50/80	approx. 130/90	approx. 200/120	approx. 700/140
Analogue output in detection range					
Voltage output R _{Last} min. 10kOhm	[V]	(0)...10 or (10)...0			
Current output, R _{Last} max. 400 Ohm	[mA]	(4)...20 or (20)...4			
Ripple of analogue output @FS	[mV]	approx. ±60	approx. ±20	approx. ±15	approx. ±20
Tracking speed of analogue output	[sec]	0.06	0.25	0.4	<2
Power supply voltage (reversal polarity protection)	[VDC]	15...30			
Ripple of supply voltage	[%]	<10			
Mean consumption, switched without load, binary output	[V]	approx. 60	approx. 60	approx. 60	approx. 65
Mean consumption, switched without load, current output	[mA]	80	80	80	85
Peak current, switched without load	[mA]	approx. 85 (0.1 ms)	approx. 85 (0.1 ms)	approx. 95 (0.2 ms)	approx. 100 (0.3 ms)
Temperature coefficient of air path	[%/°K]	-0.17 (increasing temperature → output decreases)			
Ambient temperature during operation	[°C]	-20...+50			
Sensor temperature during operation	[°C]	-20...+70			
Pressure range	[mbar _{abs}]	approx. 900...1100			
Weight without cable	[g]	approx. 90	approx. 90	approx. 90	approx. 105
Protection class	-	IP67			
Housing material	-	Polyamid glass-fibre reinforced			
Electrical connection	-	M8-connector 4-pole or integrated cable			

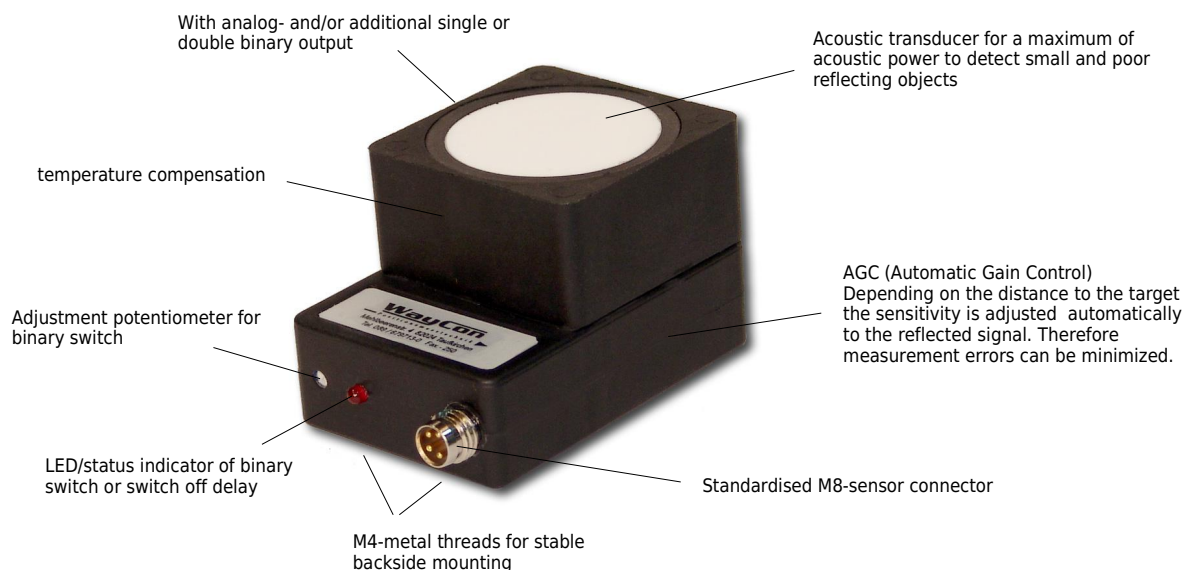

DESCRIPTION

High power density

The outstanding feature of the UN series is its high acoustic power combined with a small sensor size. This is achieved with new optimized transducers, working at high electrical voltages. Thus also small, moving and poorly reflecting objects can be safely detected. Moreover the sensors also work under high contamination. With a length of <40 mm the UN sensors are the most compact ultrasonic sensors for such high measuring ranges. Because of the new transducer sealing made of Viton® the UN sensors are very robust against many environmental influences. In particular, they are oil resistant, unlike many other ultrasonic sensors.

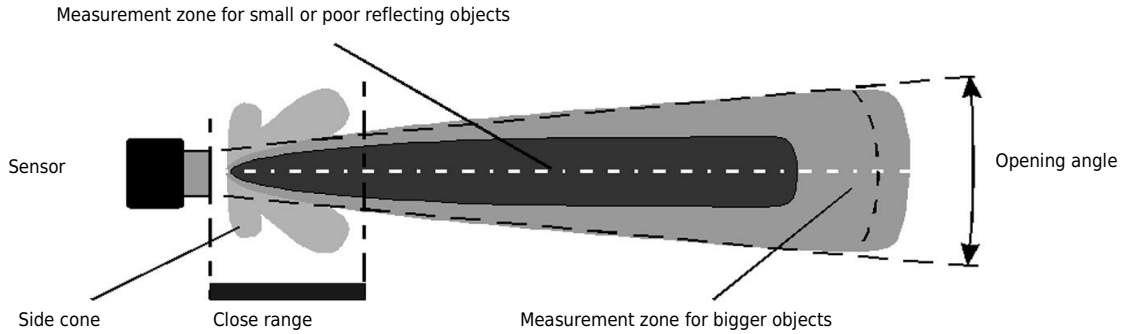

AGC (Automatic Gain Control)

AGC is exclusively used in the UN series. It adjusts automatically the detection sensitivity to the reflected signal intensity, allowing the detection of very small objects.

Temperature compensation

The temperature coefficients of the electronics and the transducer are compensated because of a special circuit.

Binary outputs

Binary outputs become active, i.e. they switch on or off, when a scanned object falls below the set distance or if it exceeds it. Each switch point has a hysteresis (see technical specifications). This is the difference between the switch on and switch off point during approach or departure. Hysteresis is necessary for an appropriate switching behaviour.

Synchronisation input (Y versions)

The ultrasonic signals can disturb each other when several sensors are focused on the same target or when sensors are mounted too close together. This can be avoided by synchronizing the sending pulses. The synchronisation leads of all sensors are connected to each other by shielded cables as short as possible. Since all sensors send simultaneously then, the current consumption increases heavily. Unused synchronisation leads shall be isolated.

Blind range

The lower detection range is called blind range. It is typical for ultrasonic sensors. In the blind range no distance measurement is possible however the pure function as a proximity switch (binary output) is possible in the blind range with certain restrictions (only bigger objects).

Inclination angle of object

Smooth surfaces can be detected up to an inclination angle of 10°. However rough and structured (granular) surfaces can be detected up to much higher angles.

Connection

All standard versions have a 4-pin M8 connector for screw or snap-on connection. The Y-versions with synchronisation input have a shielded integrated cable (l=2 m). Special cable lengths and integrated cables instead of connectors are available on demand. The cable should be kept as short as possible. Maximum cable length is approx. 100 m, if cross section area is appropriate (peak current <100 mA, use 470 µF/35 V backup capacitor close to sensor). The cable should not be mounted parallel or close to high current cables. Cables for connection to the M8 connector have to be ordered separately.

DESCRIPTION

Choice of model

The UN versions differ particularly by their different measuring ranges. The following versions are available for each measuring range:

- Fixed analogue output and 1 adjustable binary output
- 2 individually adjustable binary outputs
- Analogue output with adjustable zero and FS

The analogue outputs are available with 0...10 V or 4...20 mA and furthermore with inverted analogue outputs 10...0 V or 20...4 mA. Other versions are available on demand.

Mounting

The UN sensors have 4 threaded holes on their rear side of the housing. They can be mounted with M4 screws. 4 M4x20 screws are provided with each sensor. The UN 5000 versions shall be mounted with the damping rubber bush (included) in order to avoid acoustic cross talk. An optional mounting bracket Type UPM made of glass fibre reinforced plastic can be ordered.

Power supply

Ideally a power supply is used exclusively for the sensor. The power supply must be able to supply the short peak current of 80...100 mA for each sensor. In order to avoid disturbances the part where the sensor is mounted must be correctly earthed.

Binary outputs

The switching distance is set with a 4-turn potentiometer. An object with reasonable size and perpendicular to the sensor axis is placed at the desired distance from the sensor. First the potentiometer is turned min. 4x counter clockwise to zero (no stop). Then the potentiometer is slowly turned clockwise until the LED illuminates (NO) or expires (NC). Thus the switching distance for the binary output is set. Red corresponds to the output 1 and green to the output 2. The versions with two binary outputs have a bi-coloured LED (red/green).

Adjustable analogue outputs:

Zero and full scale (FS) of the analogue outputs can be set on the POR versions with two 4-turn potentiometers. The analogue output has to be monitored with a multi-meter.

Zero (= limit close to the sensor):

Zero (e.g. 0 V) is at the position of the sensor diaphragm when potentiometer No. 1 is turned at least 4x counter clockwise (no stop). If zero shall be in some distance from the sensor, one has to place there an object with reasonable size. The potentiometer is turned min. 4x clockwise (no stop). The reading must then be e.g. 0 V or a very small residual value (approx. 0.04 V). Then slowly turn counter clockwise until the reading starts to increase. This is then the correct setting for the zero.

Full scale (FS = far limit):

An object with reasonable size is placed at the desired distance. With potentiometer No. 2 the desired reading (e.g. 10 V) is then set. The zero and the gain can be varied within certain limits (see table below). However in the range >100 % the sensor will detect only large objects and above a certain distance no objects at all. FS must always be above zero. If the analogue output shall be inverted, i.e. zero above FS, then the inverted version 'V' must be used.

Type	Zero normal: 0 V / 4 mA inverted: 10 V / 20 mA		Gain [mm per 10 V or 20 mA]	
	Min. [mm]	Max. [mm]	Min.	Max.
UN 500	0	300	100	800
UN 1000	0	500	200	1500
UN 2500	0	1500	500	3800
UN 5000	0	3000	1000	8000

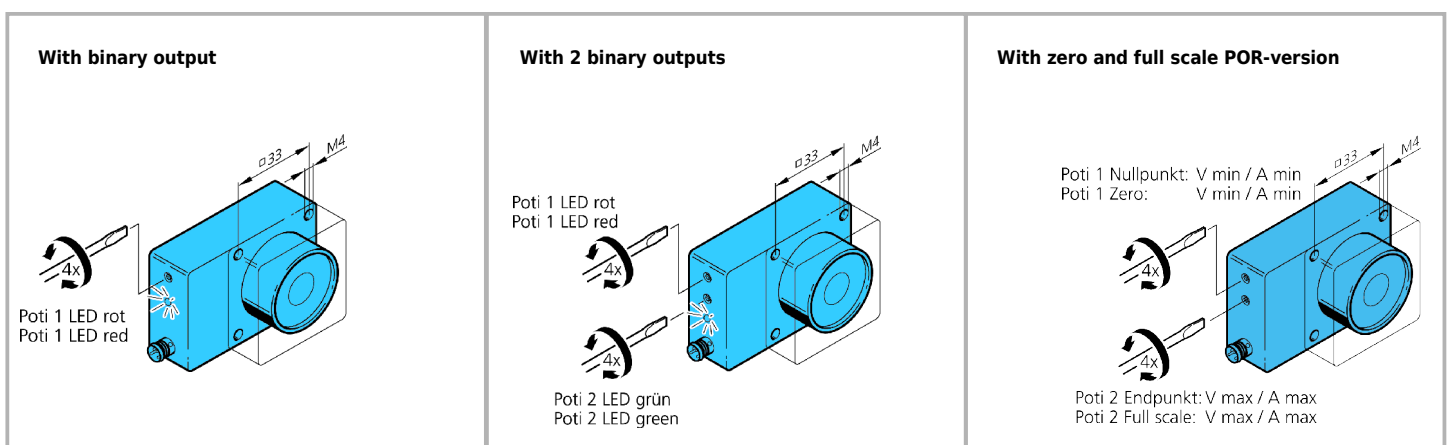

TECHNICAL DRAWING

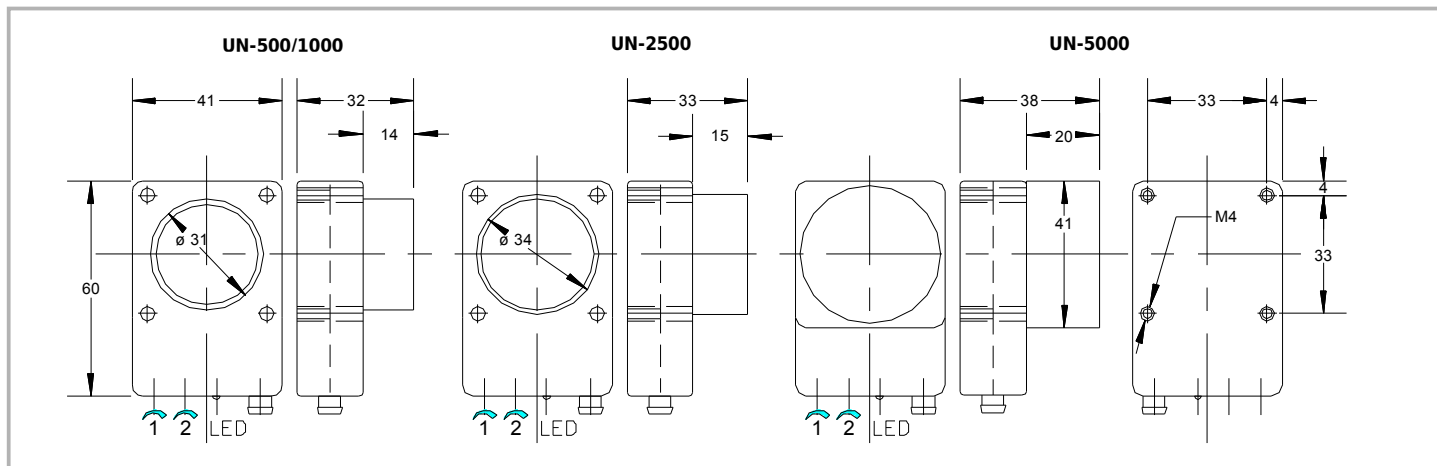

SOUND CONES

The sound beam of an ultrasonic sensor generally has the shape of a cone. The size depends on the target and its sound reflecting characteristics. Small and less reflective objects result in a smaller cone (narrower and shorter). Round objects and those with surfaces which are not perpendicular to the central axis can expand the cone. Larger objects can stretch the cone.

The exact cone shape and size can be determined only at the object itself. No disturbing objects must be between the sensor and the target within the cone. Otherwise the sensor would detect the disturbing object instead of the desired target. There are some typical cone shapes for each sensor type below. The solid line shows the range, where the sensor detects flat objects of size A4 (UN-500/1000) or A3 (UN-2500/5000) which are perpendicular to the sensor axis. The dotted line in the two left diagrams (UN 500/1000) shows the range, where round objects ($\varnothing 10\text{ mm}$) are detected (expansion or reduction of the cone) and in the two right diagrams (UN 2500/5000) the dotted line shows the range, where only large and very well reflecting objects can be detected (expansion of the cone). The size of the sonic beam is For UN 2500/5000 the dotted range is the area where the sensor detects only large and very well reflecting objects. Furthermore the size of the detection beam is influenced by air temperature and humidity. The colder and dryer the air, the larger is the beam.

The extended measuring range (above nominal range) is only available with the POR versions. No other ultrasonic sensor working at the same frequency should be within the sensing cone, close to it or opposite to it. This is only allowed when using the synchronisation option (SY-versions).

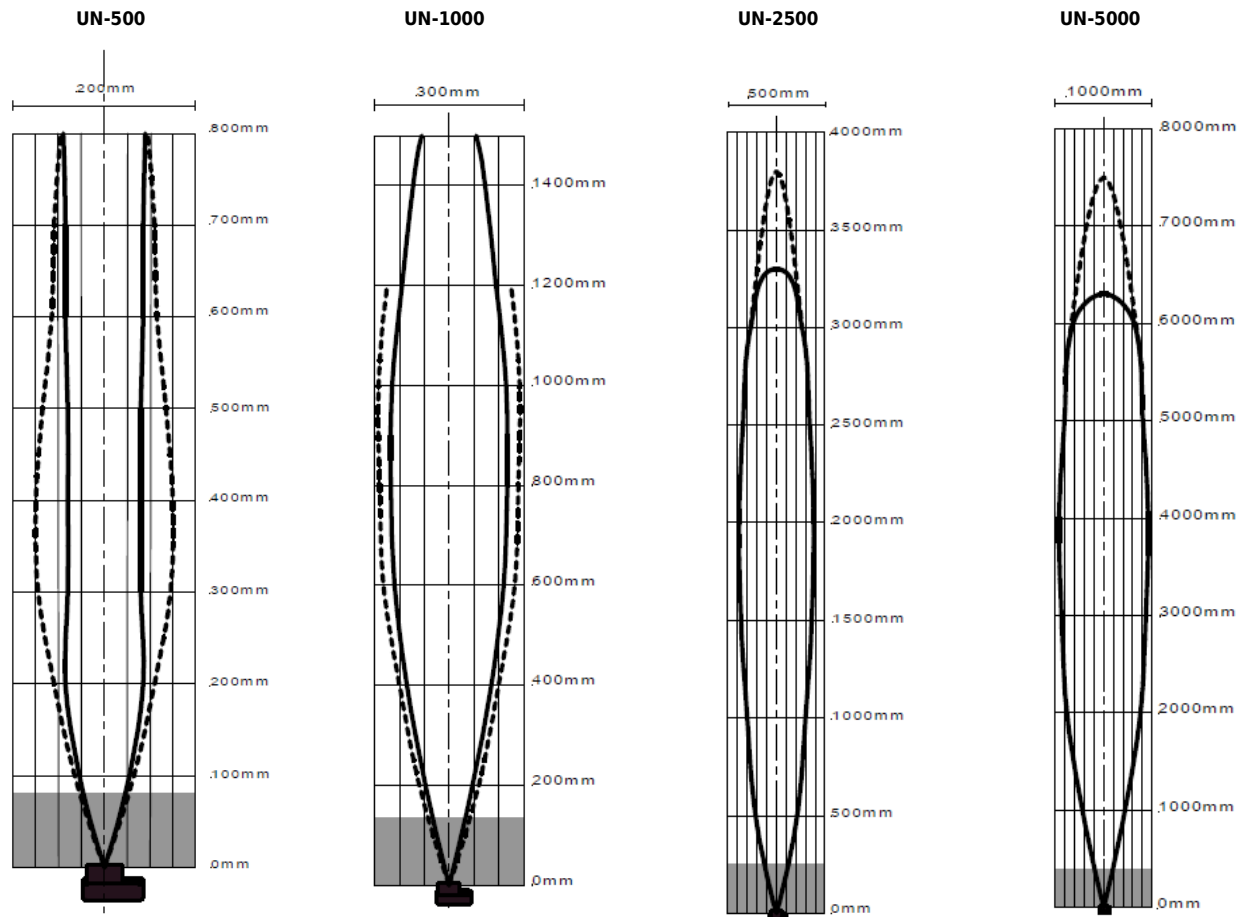

ELECTRICAL CONNECTION AND ACCESSORIES

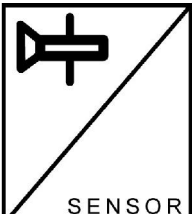
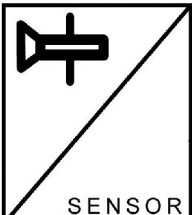
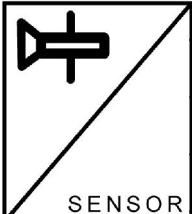
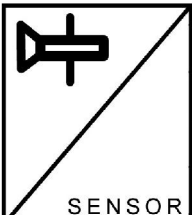
A	 <p>SENSOR</p>	braun, brown, marron weiss, white, blanc schwarz, black, noir blau, blue, bleu	+24 VDC analog output 0...10 V or 4...20 mA NPN PNP 0 V
B	 <p>SENSOR</p>	braun, brown, marron OUT 2 weiss, white, blanc schwarz, black, noir OUT 1 blau, blue, bleu	+24 VDC NPN PNP 0 V
C	 <p>SENSOR</p>	braun, brown, marron weiss, white, blanc schwarz, black, noir blau, blue, bleu	+24 VDC analog output 0...10 V analog output 4...20 V 0 V
D	 <p>SENSOR</p>	braun, brown, marron grün, green, vert gelb, yellow, jaune weiss, white, blanc grau, grey, gris	+24 VDC output „white“ output „black“ 0 V Sync. Screen

4 PIN connector

1 brown
 3 blue
 2 white
 4 black

View of the sensor

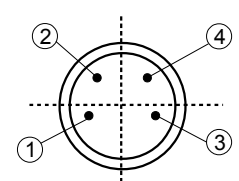

Mounting bracket
UN-Winkel

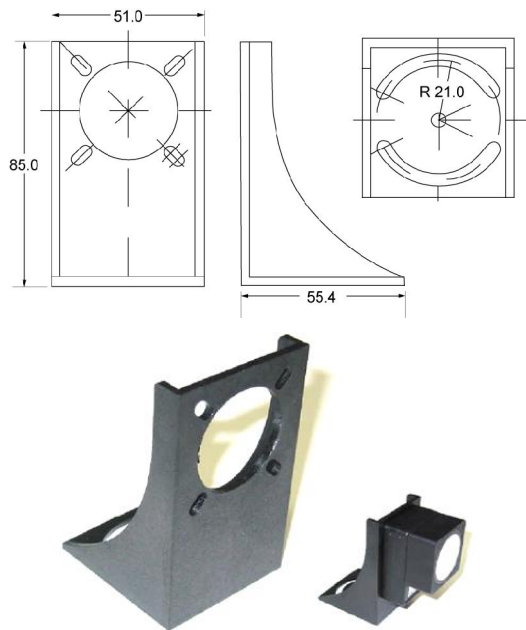

51.0
 85.0
 55.4
 R 21.0

APPLICATIONS

Level measurement

- Measuring level in small containers
- Water gauge measurement
- Monitoring liquid levels in bottling plants
- Checking for tailbacks on conveyor belts
- Monitoring contents of granular hoppers on injection moulding machines
- Distance monitoring on combine harvesters, beet lifters etc.
- Monitoring ground clearance and distance on agriculture and construction vehicles

Process control

- Controlling belt tension or sag
- Sensing and signalling valve positions
- Measuring roll diameter on reeling machines
- Monitoring the height of stacks (pallets, storehouse, assembling machines)
- Detecting material feed

Counting/Detection

- Counting onlookers at free standing sales displays or show cases
- Access supervision at rotating doors, counters etc.
- Door and lift automation
- Detecting transparent objects, foils, flat glass, bottles etc.
- Sensing objects in robot grippers
- Recognizing full or empty pallets
- Count and detect objects with 'difficult' surface
- Detect wrong parts on conveyors
- Collision protection on vehicles

Scanning of dimensions

- Determining the dimensions of packages
- Sensing the height of plants in automated green houses
- Measuring the volume of tree-trunks

ORDER CODE

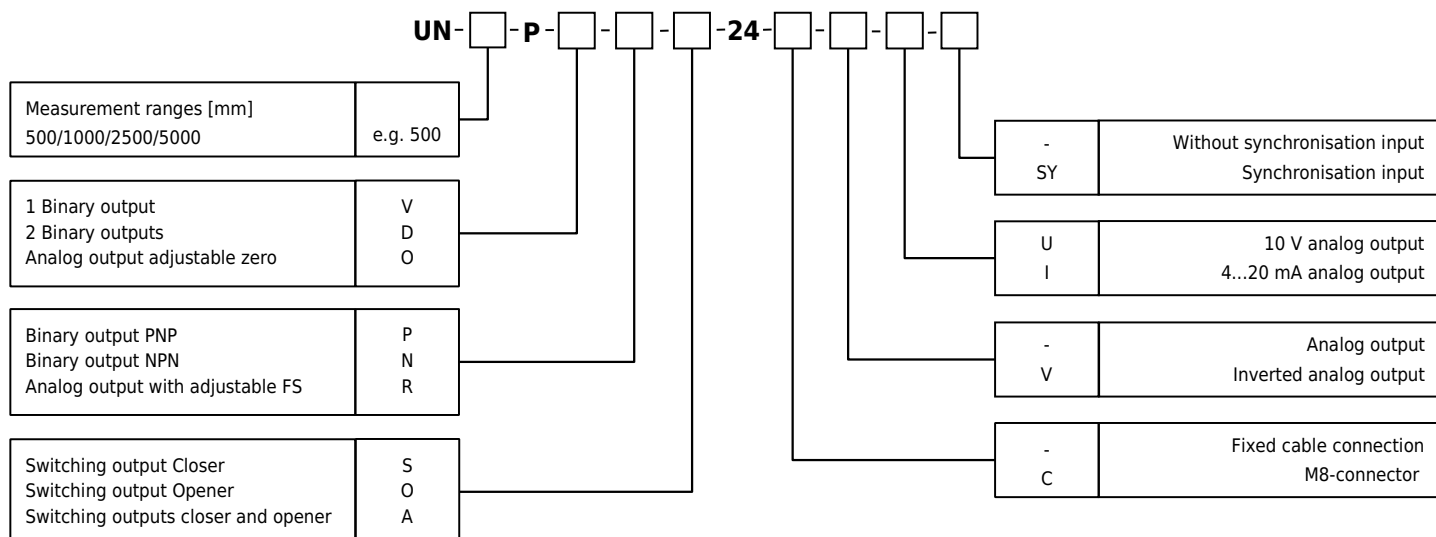

OVERVIEW

UN-500-PVPS-24-CU	PNP-closer, 0...10 V	UN-2500-PVPS-24-CU	PNP-closer, 0...10 V
UN-500-PVPS-24-CI	PNP-closer, 4...20 mA	UN-2500-PVPS-24-CI	PNP-closer, 4...20 mA
UN-500-PVPS-24-CVU	PNP-closer, 10...0 V	UN-2500-PVPS-24-CVU	PNP-closer, 10...0 V
UN-500-PVPS-24-CVI	PNP-closer, 20...4 mA	UN-2500-PVPS-24-CVI	PNP-closer, 20...4 mA
UN-500-PDPS-24-C	2 x PNP-closer	UN-2500-PDPS-24-C	2 x PNP-closer
UN-500-PDPA-24-C	1 x PNP-closer, 1x PNP-opener	UN-2500-PDPA-24-C	1 x PNP-closer, 1x PNP-opener
UN-500-POR-24-CUI	0...10 V, 4...20 mA, zero & gain adjustable	UN-2500-POR-24-CUI	0...10 V, 4...20 mA, zero & gain adjustable
UN-500-POR-24-CVUI	10...0 V, 20...4 mA, zero & gain adjustable	UN-2500-POR-24-CVUI	10...0 V, 20...4 mA, zero & gain adjustable

UN-1000-PVPS-24-CU	PNP-closer, 0...10 V	UN-5000-PVPS-24-CU	PNP-closer, 0...10 V
UN-1000-PVPS-24-CI	1 x PNP-closer, 4...20 mA	UN-5000-PVPS-24-CI	PNP-closer, 4...20 mA
UN-1000-PVPS-24-CVU	PNP-closer, 10...0 V	UN-5000-PVPS-24-CVU	PNP-closer, 10...0 V
UN-1000-PVPS-24-CVI	PNP-closer, 20...4 mA	UN-5000-PVPS-24-CVI	PNP-closer, 20...4 mA
UN-1000-PDPS-24-C	2 x PNP-closer	UN-5000-PDPS-24-C	2 x PNP-closer
UN-1000-PDPA-24-C	1 x PNP-closer, 1x PNP-opener	UN-5000-PDPA-24-C	1 x PNP-closer, 1x PNP-opener
UN-1000-POR-24-CUI	0...10 V, 4...20 mA, zero & gain adjustable	UN-5000-POR-24-CUI	0...10 V, 4...20 mA, zero & gain adjustable
UN-1000-POR-24-CVUI	10...0 V, 20...4 mA, zero & gain adjustable	UN-5000-POR-24-CVUI	10...0 V, 20...4 mA, zero & gain adjustable

OPTIONS AND ACCESSORIES

Options		Cable with connector M8, 4 pole, shielded	
SY	Synchronization input (with cable connection 2 m, shielded)	K4P2M-S-M8	2 m, M8-connector straight
V	Inverted voltage output (e. g. +10...0 V)	K4P5M-S-M8	5 m, M8-connector straight
O	Opener instead of closer	K4P10M-S-M8	10 m, M8-connector straight
-	Cable output 2 m, shielded	K4P2M-SW-M8	2 m, M8-connector angular
		K4P5M-SW-M8	5 m, M8-connector angular
UN-Winkel	Mounting bracket	K4P10M-SW-M8	10 m, M8-connector angular

Included in delivery: 4 screws M4 x 20 mm for mounting and miniature screw driver for potentiometer.

Subject to change without prior notice.

WayCon Positionsmesstechnik GmbH

E-Mail: info@waycon.de

Internet: www.waycon.de

Head Office

Mehlbeerstr. 4

82024 Taufkirchen

Tel. +49 (0)89 67 97 13-0

Fax +49 (0)89 67 97 13-250

Office Köln

Auf der Pehle 1

50321 Brühl

Tel. +49 (0)2232 56 79 44

Fax +49 (0)2232 56 79 45