

CAPACITIVE SENSORS



Series KS

Key-Features:

- extremely high resolution (Nanometer)
- Measurement ranges 50 μm up to 10 mm
- Accuracy is independent of temperature
- Temperature ranges up to +200 °C
- High class electronics, one or multi-channel
- Cost effective electronics KL
- Analog output 0...10 V
- Protection class sensors up to IP68
- Reliable measurements even in extreme environments, like nuclear radiation, high vacuum, or near 0°K etc.
- Customized probes feasible

Content:

Introduction – Applications2
Technical Data Sensor Heads3
Technical Drawing4
Sensor Cabels5
1 Channel Electronics6
Description Electronics KS7
Multichannel electronics8
Order Code9

INTRODUCTION

The design of the WayCon capacitive sensors is based on the fact that the reactance of an ideal plate capacitor is proportional to the distance between the plates. The measurement sensor is a guard ring capacitor, whose guard ring is connected to the inner shield of the double shielded measuring cable. A negative feedback amplifier keeps this protective shield tuned exactly to the potential of the sensor center electrode. This ensures in the entire measuring range an almost homogeneous field between the capacitor plates and nearly complete independence of changes in cable capacity. If an alternating current of constant amplitude and frequency passes through the sensor capacitor, the amplitude of the alternating voltage between the capacitor plates (electrode of sensor and object to be measured) is proportional to the distance between the two. A 20 kHz oscillator of highly constant amplitude and frequency provides the sensor current as well as a compensating voltage which can be selected by means of a precision potentiometer. Through a low-pass filter and an amplifier the voltage difference is conducted towards the output terminal.

As described in the above section of the operation of the distance meter, the measurement is affected by the properties of the dielectric. Generally the sensor will be used for measurements in air. The area between the sensor and the target should be completely free of dust, oil or water. If necessary this can be achieved by blowing some air through the gap between sensor and target.

Measurements in liquids

When carrying out measurements in liquids, which should only be done in special cases, one should consider that the measurements are not only affected by dust etc. but also by gas bubbles. The real distance is found by multiplying the distance (provided by the meter) with the dielectric constant (epsilon) of the fluid. Please also consider that generally the dielectric constants of liquids are temperature dependent and that the dielectric losses of the liquids used must be negligible, i.e. the liquids must be insulating.

Targets with rough surfaces

When targets have rough surfaces the distance is measured from the average profile as long as the depth of the roughness is small compared to the distance measured. The average distance is also measured in cases where the target has a curved surface.

Influence of temperature

The main reason for this is the longitudinal elongation of the sensor material. Customised versions made of INVAR are available on request. The maximum operating temperature is limited by the melting temperature of the soldering material inside the connector. Measurements at extremely low temperatures, close to the absolute zero were successfully conducted with our standard probes (Fa. Dornier, FZ Karlsruhe, ETH Zürich).

Magnetic fields

Can be neglected, as long as there is no exertion of force to the measurement system. On request the sensor heads can be made of non-magnetic material, like Titanium.

Radioactive radiation

has no influence on measurements performed by capacitive sensors. Appropriate insulation materials guarantee long term operation, without failure.

Specific resistance

The relatively low carrier frequency of the system allows measurement at materials in the micro ohm to kilo ohm range ($\mu\text{Ohm cm}$ up to $> 1000 \text{ Ohm cm}$) without special recalibration. Therefore the whole range of measuring on silicon semiconductors is also covered.

This fact has great relevance when measuring on casehardened shafts in the mechanical engineering sector, because an inhomogeneous micro structure has no influence on the measurement results. There is almost no other method to control the displacement of a shaft running in oil in a sliding bearing than by a capacitive sensor.

Measurements on insulation material

The capacitive sensors can also be used to measure the thickness of non conductive materials such as plastics, foils, quartz, glass, ceramics, etc.

Averaging

The sensors active area measures the average distance to the object. The roughness of an objects surface is automatically averaged by the system. This is feature may be of advantage when small small irregularities should not be observed.

Customised probes (sensor heads)

No other measurement principle allows such cheap and simple adaptations of the probe housing or the active area according to the customer needs. The reason for this is the pure mechanical construction consisting of conducting electrodes and insulating barrier sheets (plastics, ceramics, glass). Some examples are shown on page 3.

EXAMPLE APPLICATIONS

- Dynamic measurement on turbines and motors
- Shaft movements in bearings
- Rotor vibrations
- Smoothness of running of machine tools
- Displacement measuring on slide bearings
- Vibrations in a plane
- Concentricity measuring on axles
- Measuring of modulus of elasticity and thermal expansion
- Distance measurements in lowest temperature technique
- Check-up of gauges
- Tolerance verification of mass-produced parts, e.g. for matching mechanical components
- Thickness control of thin metallic sheets
- Control of plastic foil thickness on production machines
- Measuring of thickness, taper and bow of silicon wafers for the semiconductor production
- and many more...



The worlds smallest capacitive sensor

TECHNICAL DATA - STANDARD SENSORS



Sensor	K0005	K0020	K0050	K0100	K0200	K0300	K0500	K1000
Measurement range [mm]	0...0.05	0...0.2	0...0.5	0...1	0...2	0...3	0...5	0...10
Linearity *	±0.2%							
Dynamic resolution *	0.01%							
Sensitivity [µm/V]	5 ±0.2%	20 ±0.2%	50 ±0.2%	100 ±0.2%	200 ±0.2%	300 ±0.2%	500 ±0.2%	1000 ±0.2%
Temperature error sensitivity	-3.0 x 10 ⁻⁶ /K	-0.3 x 10 ⁻⁶ /K	-11.0 x 10 ⁻⁶ /°C	-1.1 x 10 ⁻⁶ /K	-3.0 x 10 ⁻⁶ /K	-3.0 x 10 ⁻⁶ /K	-3.0 x 10 ⁻⁶ /K	-3.0 x 10 ⁻⁶ /K
Tolerance sensitivity [%] **	±2	±1	±0.5	±0.5	±0.5	±0.5	±0.5	±0.5
Temperature stability [µm/K]	0.03	0.03	0.06	0.06	0.17	0.17	0.17	0.17
Operating temperature [°C]	-50...+200	-50...+200	-50...+200	-50...+200	-50...+200	-50...+200	-50...+200	-50...+200
Diameter active area [mm]	1.1	2.3	3.8	5.5	7.9	9.8	12.6	17.7
Minimum diameter target [mm]	3	6	7	9	17	27	37	57
Weight [g]	1.7	2.5	5.7	7.1	61	95	120	230
Material housing (DIN EN 10 027-2)	1.3912	1.3912	1.4104	1.4104	1.4305	1.4305	1.4305	1.4305
Type of connection								

* dependent on the connected electronics

** in case of a sensor change

EXAMPLES FOR CUSTOM SENSORS



TECHNICAL DRAWING

<p>K0005</p> <p>12 ^{+0.00}/_{-0.10}</p> <p>5</p> <p>∅6 e7</p> <p>∅3</p> <p>∅6 h6</p> <p>clamping area</p>	<p>K0020</p> <p>12 ^{+0.00}/_{-0.20}</p> <p>5</p> <p>∅6 e7</p> <p>∅6 h6</p> <p>clamping area</p>
<p>K0050</p> <p>20 ^{+0.00}/_{-0.20}</p> <p>∅8 h7</p>	<p>K0100</p> <p>20 ^{+0.00}/_{-0.20}</p> <p>11</p> <p>∅10 e7</p> <p>∅10 h6</p> <p>clamping area</p>
<p>K0200</p> <p>30 ^{+0.00}/_{-0.20}</p> <p>∅20 h7</p>	<p>K0300</p> <p>30 ^{+0.00}/_{-0.20}</p> <p>20</p> <p>∅30 h7</p> <p>∅20 h7</p>
<p>K0500</p> <p>30 ^{+0.00}/_{-0.20}</p> <p>20</p> <p>∅40 h7</p> <p>∅20 h7</p>	<p>K1000</p> <p>30 ^{+0.00}/_{-0.20}</p> <p>20</p> <p>∅60 h7</p> <p>∅20 h7</p>

All dimensions in mm.

SENSOR CABLES



The cable is part of the resonant circuit and must therefore not be shortened, bent or changed in any other way. The cable is a specially manufactured triaxial-cable, designed for best measurement results. Please use original cables only.

Cable	L13-11	L13-12	L13-13	L13-14	L33-11	L33-12	L33-13	L33-14
Length [m]	1	1	1	1	3	3	3	3
For probes	K0100	K0005	K0100	K0005	K0100	K0005	K0100	K0005
	K0200	K0020	K0200	K0020	K0200	K0020	K0200	K0020
	K0300	K0050	K0300	K0050	K0300	K0050	K0300	K0050
	K0500		K0500		K0500		K0500	
	K1000		K1000		K1000		K1000	
Cable diameter [mm]	3							
Operating temperature [°C]	-50...+150 °C							

L13-11 / L33-11

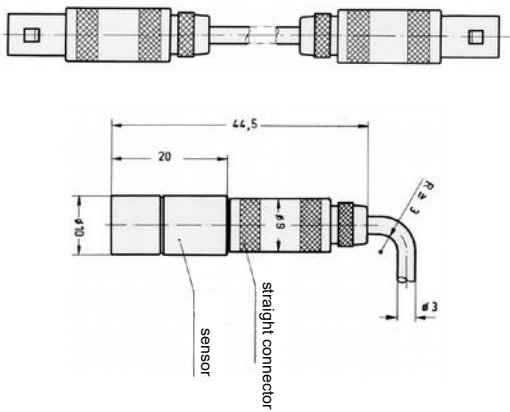

L13-12 / L33-12

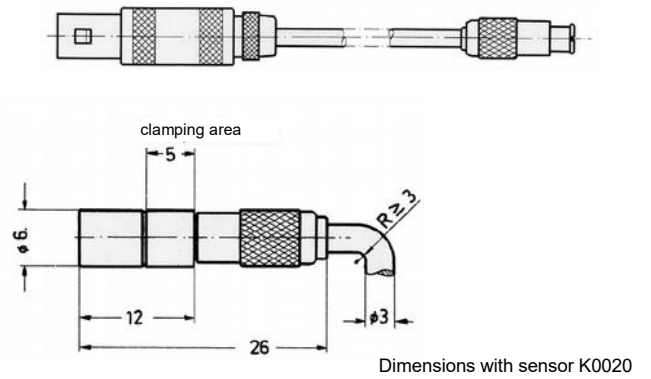

L13-13 / L33-13

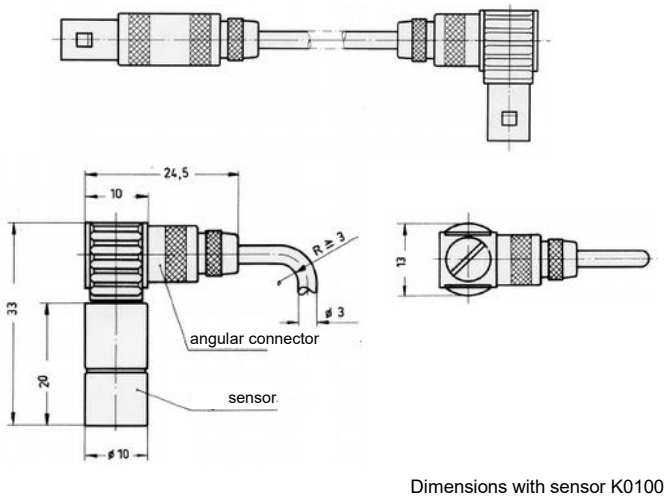

L13-14 / L33-14

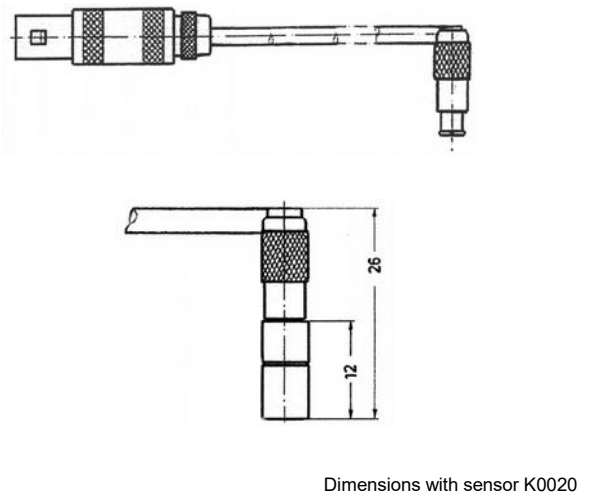

1 CHANNEL ELECTRONICS

The K series is designed for non - contact measurement of the distance between the end face of a pick up and the conductive surface of a target. Pick-up and target form a capacitor. The dielectric must be defined, its loss must be negligible. The distance - meter is calibrated in units of length for materials with a relative dielectric constant of $\epsilon_r = 1$ and it is equipped with a indicating instrument and digital scale potentiometer. The indicating instrument makes possible the use of the deflection method for static measurements. For static and dynamic measurements an output terminal for indicating and recording instruments provides a voltage which is proportional to the distance measured. The potentiometer allows a defined zero - suppression of the output voltage.



Display	4.5 digits	4.5 digits	-
Power supply	115 V / 230 V , 50 Hz / 60 Hz	115 V / 230 V , 50 Hz / 60 Hz	100...240 V, 50 Hz / 60 Hz
Power consumption	9 VA	18 VA	5 VA
Operating temperature	0...50 °C	0...50 °C	0...70 °C / 0...80 °C
Storage temperature	-20...70 °C	-20...70 °C	-20...80 °C / -20...90 °C
Warm up time	30 min	30 min	3 min
Weight	3.7 kg	4.0 kg	0.35 kg / 0.70 kg
Dimensions	W 180 x H 150 x D 265 mm	W 260 x H 150 x D 265 mm	W 64 x H 35 x D 115 mm / W 80 x H 60 x D 170 mm
Upgradeable to more channels	no	yes	no
Housing construction	19" system 3 HE	19" system 3 HE	aluminium die-cast
Amplifier with trimming potentiometer	yes	no	no
Voltage output	„NORM.“	„OUT“	„OUT“
Sensitivity *	10 V/MB $\pm 0.2\%$	10 V/MB $\pm 0.2\%$	10 V/MB $\pm 0.2\%$
Linearity (at 0...40°C, dielectric media: air)	$\pm 0.2\%$	$\pm 0.2\%$	$\pm 0.4\%$ / $\pm 0.2\%$
Temperature error sensitivity	<0.01 %/°C	<0.01 %/°C	<0.02 %/°C / <0.01 %/°C
Temperature drift offset (U _a = 0 V)	< ± 0.3 mV/°C	< ± 0.3 mV/°C	-
Long term drift offset (U _a = 0 V)	< ± 1 mV/week, < ± 10 mV/year	< ± 1 mV/week, < ± 10 mV/year	-
Max. output voltage	± 10 V	± 10 V	+10V
Max. output current	± 5 mA	± 5 mA	+5 mA
Frequency dependence	0...4 kHz: $\pm 1\%$, 0...6 kHz: -3 dB	0...4 kHz: $\pm 1\%$, 0...6 kHz: -3 dB	0...500 Hz (-3 dB)
Noise voltage	U _a = 0 V: <5 mV _{ss} , typ. 2 mV _{ss} / U _a = 10 V: <10 mV _{ss}		<10 mV _{ss}
Connector	BNC	BNC	LEMO / BNC
Additional Output **	„VARI“		
Sensitivity factor	0...10	-	-

* These specifications are valid for the use of the probe K0100 (measurement range 0...1000 μm). The display and its labeling are designed for 0...1000 μm .

All other probes shown on page 3 may also be used with the electronics. The reading has to be converted with an integer factor according to the used probe.

** U_a = 0V: The output voltage can be adjusted to zero over the full scale by using the potentiometer. By doing this the influence of drift, temperature and noise are the smallest (= compensation method) >>> Especially during long-term measurement with small value changes this method is recommended.

TECHNICAL DRAWING

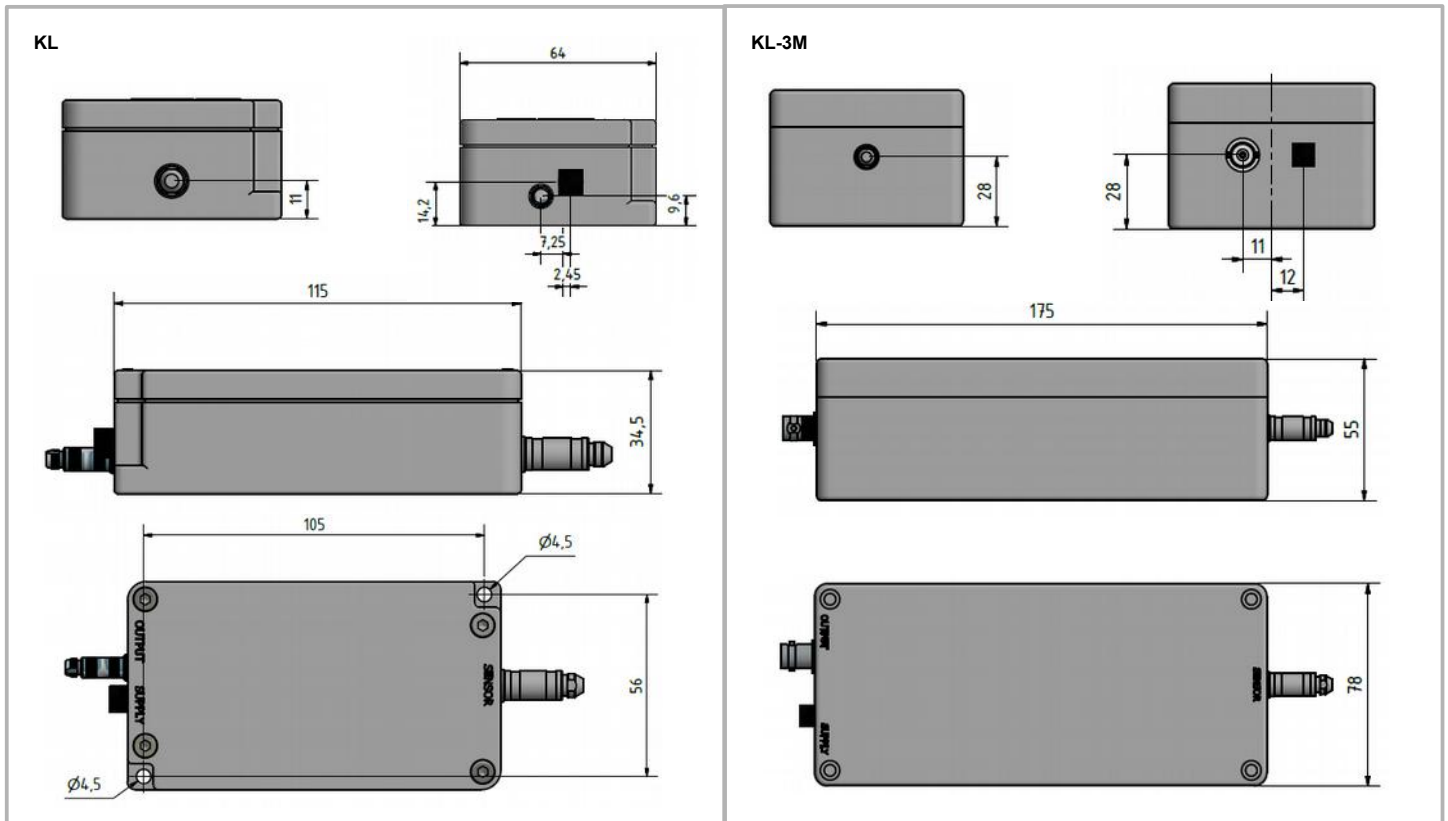

DESCRIPTION ELECTRONICS KS

Features

The device measures, without contact, the distance between the front side of the sensor and the conductive surface of the target. Sensor and target form an electrical capacitor. The device is calibrated in length units. It includes a display and a compensator with digits. Therefore static measurements with the compensation method as well as the deflection method are possible. An outlet provides a distance proportional voltage value for static and dynamic measurements. The zero point of the output voltage may be accurately shifted by means of the compensator.

Construction and working principle

The design of the KS electronics is based on the fact that the reactance of an ideal plate capacitor is proportional to the distance between the plates. The measurement sensor is a guard ring capacitor, whose guard ring is connected to the inner shield of the double shielded measuring cable. A negative feedback amplifier keeps this protective shield tuned exactly to the potential of the sensor center electrode. This ensures in the entire measuring range an almost homogeneous field between the capacitor plates and nearly complete independence of changes in cable capacity. If an alternating current of constant amplitude and frequency passes through the sensor capacitor, the amplitude of the alternating voltage between the capacitor plates (electrode of sensor and object to be measured) is proportional to the distance between the two. A 20 kHz oscillator of highly constant amplitude and frequency provides the sensor current as well as a compensating voltage which can be selected by means of a precision potentiometer. The sensor voltage and the compensating voltage are rectified by means of a rectifier with high linearity and zero stability. Through a low-pass filter and an amplifier the voltage difference is conducted towards the output terminal. The display shows the distance between the object to be measured and the front side of the sensor.

As shown in the description above the measurement is affected by the properties of the dielectric. Generally the device will be used for measurements in air. The area between the sensor and the target should be completely free of dust, oil or water. If necessary this can be achieved by blowing some air through the gap between sensor and target.

Typical applications

The KS system can be used to measure shaft movements in bearings, rotor vibrations, the smoothness of running of machine tools, static and dynamic deformations, vibrations in a plane, module of elasticity, coefficient of thermal expansion, circularity of shafts and bore holes and so on.

Changing the sensor head

Due to the small sensitivity tolerances of the sensors it is possible to exchange sensors without recalibrating the KS electronics. A total accuracy of $\pm 0.5\%$ is still guaranteed.

Additional outlets

For special applications the sensitivity of the output voltage may be adjusted by a factor 0 to 10 (Socket "VARI." and adjustment by "FACTOR")

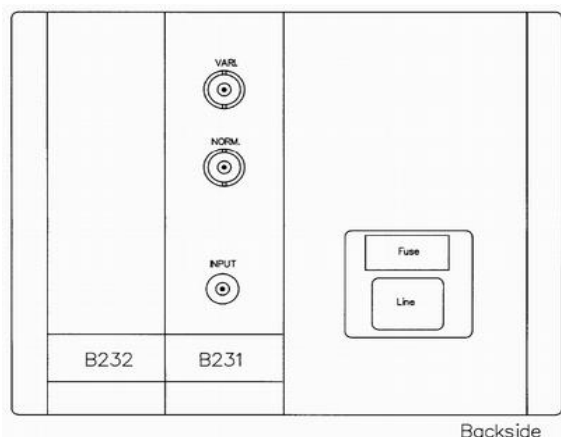

Backside

MULTICHANNEL ELECTRONICS

The K series is designed for non - contact measurement of the distance between the end face of a pick up and the conductive surface of a target. Pick-up and target form a capacitor. The dielectric must be defined, its loss must be negligible. The distance - meter is calibrated in units of length for materials with a relative dielectric constant of $\epsilon_r = 1$ and it is equipped with a indicating instrument and digital scale potentiometer. The indicating instrument makes possible the use of the deflection method for static measurements. For static and dynamic measurements an output terminal for indicating and recording instruments provides a voltage which is proportional to the distance measured. The potentiometer allows a defined zero - suppression of the output voltage.



	KS2...KS8
Number of channels	1...8
Connectable probes	All models shown on page 3
Linearity (at 0...40°C, dielectric media: air)	±0.2% of full scale
Repeatability	±0.05% of full scale
Sampling rate	4.5 kHz
Display	4.5 digits
Power supply	115 V / 220 V, 50 Hz / 60 Hz
Power consumption	depending on the number of channels 18...46 VA
Operating temperature	0...50 °C
Storage temperature	-20...70 °C
Warm up time	30 min
Weight	depending on the number of channels 4.0...8.0 kg
Dimensions	H 150 x W depending on the number of channels 260...470 x D 265 mm
Upgradeable to more channels	yes, (maximum is 8)
Housing construction	19" system 3 HE
Voltage output	"OUT"
Sensitivity *	10 V/FS ±0.2%
Linearity (at 0...40°C, dielectric media: air)	±0.2%
Temperature error sensitivity	<0.01%/°C
Temperature drift offset (Ua = 0 V)	<±0.3 mV/°C
Long term drift offset (Ua = 0 V)	<±1 mV/week, <±10 mV/year
Max. output voltage	±10 V
Max. output current	±5 mA
Frequency dependence	0...4 kHz: ±1%, 0...6 kHz: -3 dB
Noise voltage	Ua= 0 V: <5 mV _{SS} , typ. 2 mV _{SS} / Ua= 10 V: <10 mV _{SS}

* These specifications are valid for the use of the probe K0100 (measurement range 0...1000 µm). The display and its labeling are designed for 0...1000 µm.

All other probes shown on page 3 may also be used with the electronics. The reading has to be converted with an integer factor according to the used probe.

ORDER CODE

K

Sensor head, measurement range [mm]	
0...0.05	0005
0...0.2	0020
0...0.5	0050
0...1.0	0100
0...2.0	0200
0...3.0	0300
0...5.0	0500
0...10.0	1000

L

Cable version measurement range ≤ 0.5 mm	
2 x straight connector, 1 m cable	13-12
1 x angular, 1 x straight connector, 1 m cable	13-14
2 x straight connector, 3 m cable	33-12
1 x angular, 1 x straight connector, 3 m cable	33-14
Cable version measurement range ≥ 1.0 mm	
2 x straight connector, 1 m cable	13-11
1 x angular, 1 x straight connector, 1 m cable	13-13
2 x straight connector, 3 m cable	33-11
1 x angular, 1 x straight connector, 3 m cable	33-13

K

Electronics	
1 channel, 0...10 V output, with display	1
1 channel, 0...10 V output, without display, 1 m cable	L
1 channel, 0...10 V output, without display, 3 m cable	L3M
1 channel, 0...10 V output, with display upgradable	S1
2 channel, 0...10 V output, with display	S2
3 channel, 0...10 V output, with display	S3
4 channel, 0...10 V output, with display	S4
5 channel, 0...10 V output, with display	S5
6 channel, 0...10 V output, with display	S6
7 channel, 0...10 V output, with display	S7
8 channel, 0...10 V output, with display	S8

Subject to change without prior notice.

WayCon Positionsmesstechnik GmbH

email: info@waycon.de
internet: www.waycon.de

Head Office

Mehlbeerstr. 4
82024 Taufkirchen
Tel. +49 (0)89 67 97 13-0
Fax +49 (0)89 67 97 13-250

Office Köln

Auf der Pehle 1
50321 Brühl
Tel. +49 (0)2232 56 79 44
Fax +49 (0)2232 56 79 45