

LINEAR DISPLACEMENT TRANSDUCER TYPE LDT 5 HRW S (for high temperature, high pressure and radioactive environments)

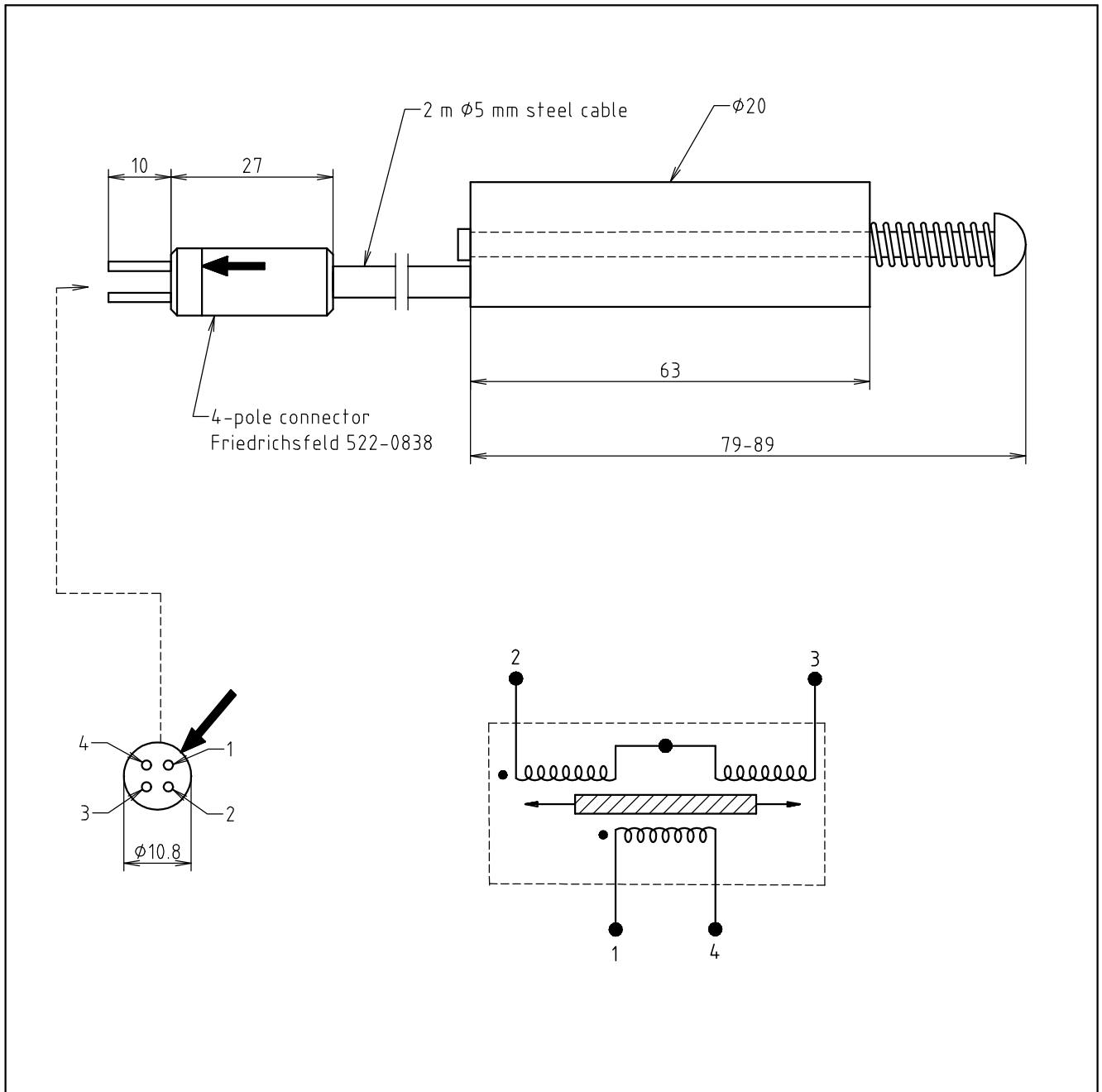

DESCRIPTION

The displacement transducer LDT 5 HRW S is designed to work in harsh environments. The transducer is hermetically sealed by laser welding and completely made of inorganic material. The coil form is made of the ceramic material "Macor" from "Corning Glass" and wound with a ceramic insulated silver wire. The transducer can stand a gamma dose of 70.000 megarads. The stainless steel cable is terminated with a 4-terminal feed through to protect the ceramic insulation in the steel cable from moisture absorption.

SPECIFICATIONS

Linear range	± 5 mm
Non-linearity	< 0.6 % (range ± 5 mm) < 0.2 % (range ± 1 mm)
Supply voltage	Nom. 5 V _{RMS}
Carrier frequency	Nom. 5 kHz (400 Hz – 10 kHz)
Input impedance (5 kHz)	500 Ω
Output impedance (5 kHz)	500 Ω
Carrier phase shift (5 kHz)	7 °
Temperature range	-200 °C to +400 °C
Temperature coefficient of sensitivity (5 kHz)	< 0.02 %/°C
Pressure max	200 bar
Mechanical shock	1000 g for 6 ms (half sine) according to IEC 68-2-27 test Eb, will not affect calibration
Weight (incl. 2 m cable)	200 g
Cable	Lenght 2 m (standard), diameter ø5 mm
Electrical connections	4-terminal connector (Friedrichfeld 522-0838)
Gaging force (S – version)	500 pond
Material	
Housing	Stainless steel Sandviken 18.02
Inner tube	Stainless steel AISI 316 L
Cable	Stainless steel AISI 316