

# LVDT

## Inductive Position Transducer



### SM Series

#### Key-Features:

- Measurement ranges 2...200 mm
- External, or cable electronics with cable break detection
- Linearity up to  $\pm 0.10\%$  of full scale
- Housing  $\varnothing 12$  mm, clamp  $\varnothing 8$  mm h6
- Protection class IP67, optional IP68
- Sensor working temperature up to 200 °C
- Spring loaded versions available
- Customized versions available

#### Content:

## INTRODUCTION

LVDTs (Linear Variable Differential Transformers) are inductive sensors excellent for use in harsh industrial environments, e.g. high temperature and pressure ranges, as well as high accelerations and measuring cycles.

The SM series offers ultimate reliability and precision in a small size, and is designed for industrial and lab use. The SM series is also available as a pressurized hydraulic model to 400 bar for installation directly in hydraulic cylinders. (See data sheet SM-HYD and SM-F18)

As of 2013 IMCA and KAB electronics (explanation see page 5) have a built-in cable breakage monitoring and are entirely galvanically isolated. The signal output is optimized for interference compatibility with very low residual noise. The guarantee for ultimate resolution and measuring accuracy.

## TECHNICAL DATA

Sensor							
Measurement range FS [mm]	0...2	0...5	0...10	0...25	0...50	0...100	0...200
Linearity [% of FS]	0.30 % (0.20 % optional, 0.10 % for selected models)						
Types	spring loaded (up to range 0...100 mm), free core, push rod guided/unguided						
Protection class	IP67, optional IP68						
Vibration stability DIN IEC68T2-6	10 G						
Shock stability DIN IEC68T2-27	200 G/2 ms						
Supply voltage/ frequency	3 V <sub>eff</sub> /3 kHz						
Supply frequency	2...10 kHz						
Temperature range	-40...+120 °C (150 °C optional, option H, 200 °C on request)						
Mounting	ø 8 mm h6 clamp diameter or ø 12 mm						
Housing	nickel-plated steel						
Connection	cable output or M12-connector with coupling nut						
cable TPE (standard)	ø 4.5 mm, 0.14 mm <sup>2</sup> , non-halogen, suitable for drag chains						
PTFE (option H)	ø 4.8 mm, 0.24 mm <sup>2</sup> , max. temperature 200 °C, UL Style 2895						
Max. cable length	100 m between sensor and electronics						
<b>Spring loaded version (up to range 100 mm)</b>							
Spring force (middle of range) [N]	0.9	0.9	0.9	0.95	0.95	-	-
Max. cycles of tip at 1 mm amplitude [Hz]	55	50	50	35	20	-	-
Spring stiffness [N/ mm]	0.29	0.2	0.12	0.06	0.04	-	-
Life cycle	> 10 million cycles						
<b>Free core/ push rod/ push rod guided</b>							
Max. acceleration of core/ push rod	100 G						
Life cycle	infinite						
Weight (approx., without cable) [g]	36	42	47	59	85	136	238

Electronics	IMCA external electronics (built-in)	KAB cable electronics
Output signal	0...20 mA, 4...20 mA (load < 300 Ohm) 0...5 V, ± 5 V (load > 5 kOhm) 0...10 V, ± 10 V (load > 10 kOhm)	4...20 mA (load < 300 Ohm) 0...5 V, ± 5 V (load > 5 kOhm) 0...10 V, ± 10 V (load > 10 kOhm)
Temperature coefficient	-0.0055, ±0.002 %/K	
Resolution*	0.04% of FS	
Corner frequency	300 Hz/-3 dB (6-pole Bessel)	
Isolation stability	> 1000 VDC	
Power supply	9...36 VDC	
Current consumption	75 mA at 24 VDC 150 mA at 12 VDC	65 mA at 24 VDC 140 mA at 12 VDC
Sensor supply	3 V <sub>eff</sub> , 3 kHz (adjustable, 1-18 kHz)	
Working temperature	-40...+85 °C	
Storage temperature	-40...+85 °C	
Housing	polyamide PA6.6, meets UL94-VO	aluminium
Mounting	on DIN EN-rail	-

\* 98.5% confidence interval (confidence limit)

# TECHNICAL DIMENSIONS

range (FS) [mm]	body length B radial cable/ connector [mm]	body length C connector M12[mm]	core length D [mm]	push rod length E [mm]
0...2	64	67	22	54
0...5	70	73	25	60
0...10	80	83	30	70
0...25	110	113	45	100
0...50	160	163	70	150
0...100	260	263	120	250
0...200	460	463	220	450

Other measurement ranges are available on request.

**type:**

free core: delivery D: core, the core extension made of non-magnetic material must be added by the customer.

push rod unguided: delivery E: core + core extension

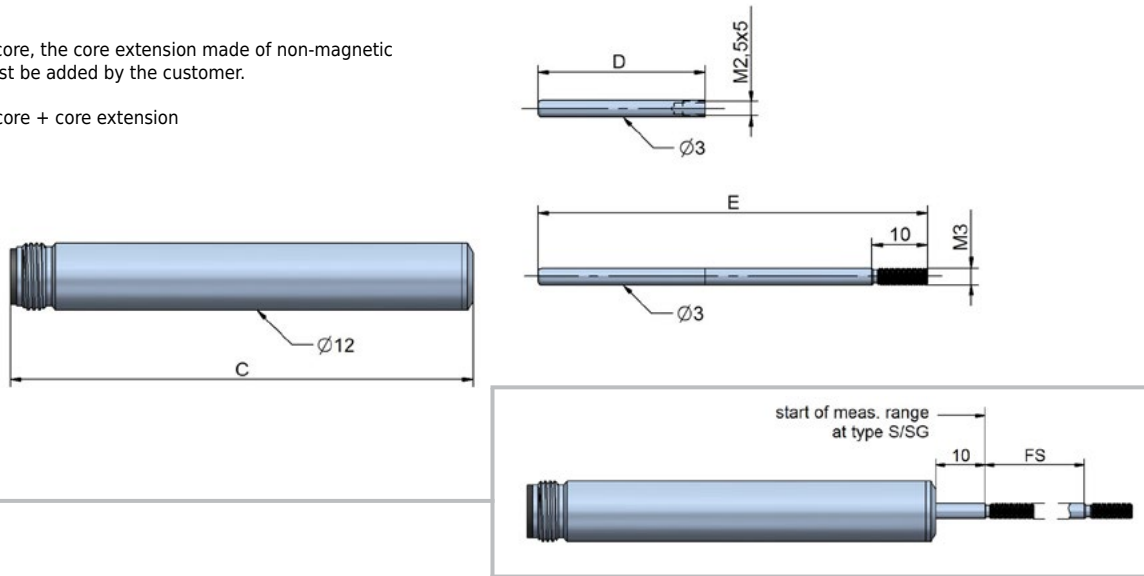

**type:** push rod guided

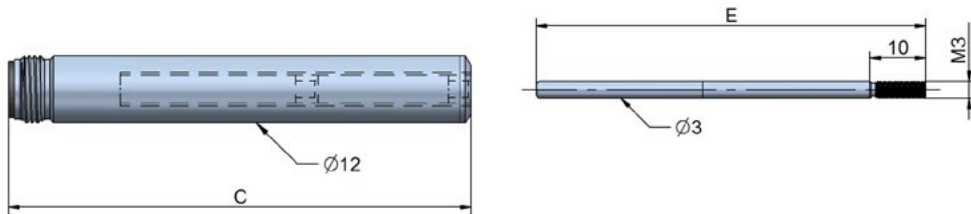

**type:**

spring loaded (up to range 0...100 mm)

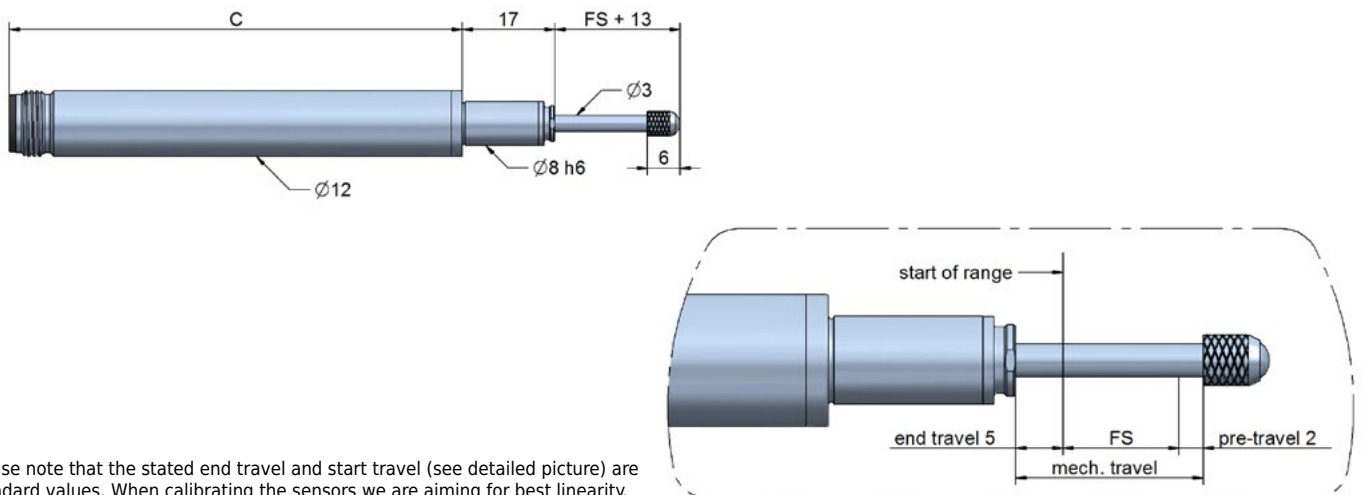

Please note that the stated end travel and start travel (see detailed picture) are standard values. When calibrating the sensors we are aiming for best linearity.

## SENSOR TYPES

### axial cable output

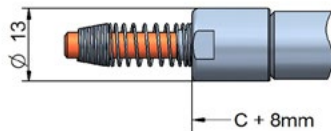

Sensors with cable output have a cable fitting and a spring for bend protection of the cable.

For installation, the bending radius should not be less than 3 times the cable diameter. The standard cable length is 2 m.

Instruments with option H for temperatures up to 150 °C/ 200°C feature a PTFE cable.

### radial cable/ connector output

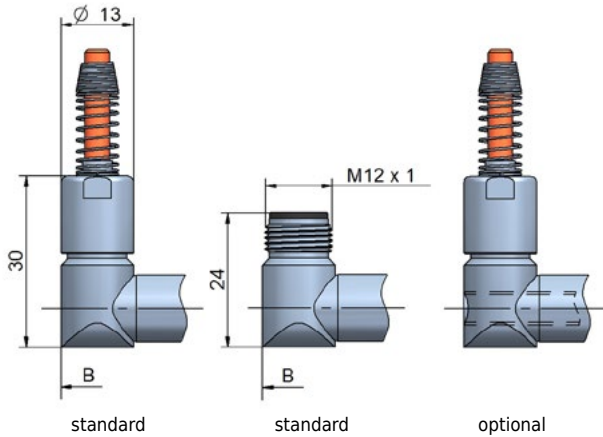

For normal application the sensors have a closed rear end body.

Sensors that feature a radial cable output can be supplied with a through hole on request (option RO). Please use this version for applications at heavy dirt exposure. The movement of the push rod removes dirt from the sensor and conveys it to the rear. The standard cable length is 2 m.

### connector output (cable with straight or angular connector)

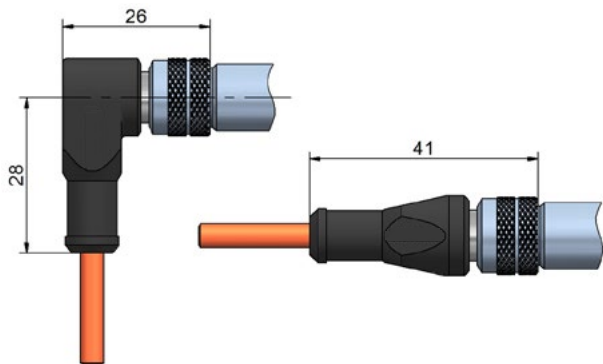

For sensors with connector output the cable has to be ordered separately. You can choose from a cable with a straight connector or with an angular connector.

The connector is protected from accidental removal by a threaded fitting (M12). The cable lengths are 2/ 5/ 10 m.

The connector pair has protection class IP67.

The total length of the sensor with connector is:  
body length of the connector M12 (see table) + 20 mm (angular connector)  
body length of the connector M12 (see table) + 37 mm (straight connector)

### gaiter (option FB for SM2...SM25)



A gaiter is available for sprung loaded sensors to protect the mechanics from fouling.

Note: The gaiter is also available as retrofit kit for measurement ranges from 2 to 25 mm.

- The measurement range of sensors with 25 mm is reduced to 20 mm!
- The working temperature is limited to 0...+120 °C.

### rod seal / wiper

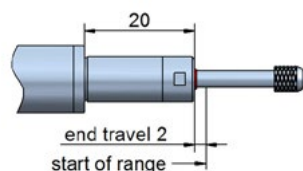

A special design of a fluorocarbon scaling integrated in the sensor front cap combines sealing and wiping and ensures a smooth motion of the mechanics.

Note: The end travel is reduced to 2 mm!

## AC-OUTPUT

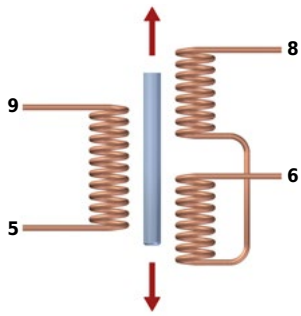

### assignment for TPE-cable:

white (5): primary 2  
 black (6): secondary 2  
 brown (9): primary 1  
 blue (8): secondary 1

### assignment for PTFE-cable:

white (5): primary 2  
 green (6): secondary 2  
 yellow (9): primary 1  
 brown (8): secondary 1

### assignment M12-connector:

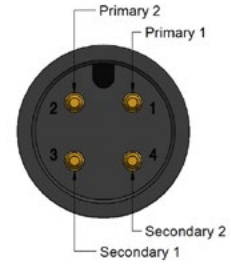

## CABLE ELECTRONICS KAB



cable length sensor-electronics  
 1m, 4m, 9m

cable length 1m



sensor

connection

### assignment for TPE-cable:

brown: supply V+  
 blue: GND  
 black: output GND  
 white: output signal

### assignment for PTFE-cable:

yellow: supply V+  
 brown: GND  
 green: output GND  
 white: output signal

If not specified otherwise the cable electronics is placed at 1 m from the end of the cable. On request in your order, however, the cable electronics can be placed at any position.

## EXTERNAL ELECTRONICS IMCA



external electronics IMCA  
 (for DIN-rail mounting)

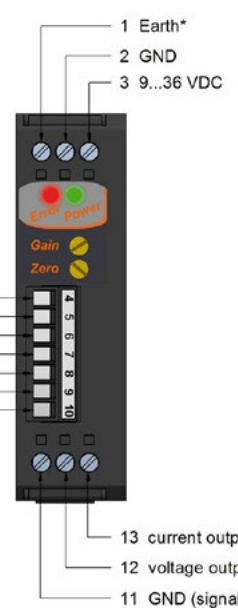
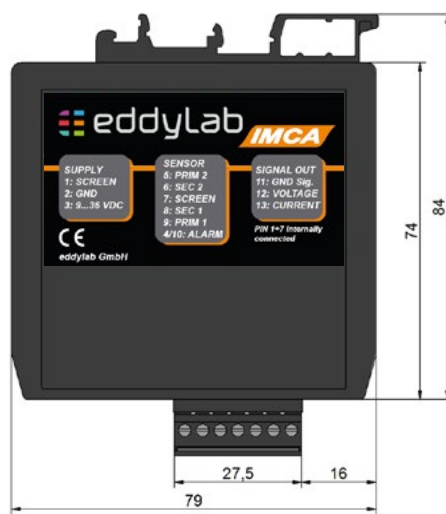

### Connection

The external electronics IMCA is designed to be installed in switch cabinets (Din-rail mounting). The connection to the sensor is conducted as connector with push-in spring connection.

At harsh EMC environments, it is possible to install the electronics at a max. distance of 100 m in a switch cabinet. A twin twisted pair cable (4-cores, minimum cross section 0,5 mm<sup>2</sup>), single or double shielded, is to be used for the further wiring to connect the external electronics to the system. It is recommended to ground the shield in the switch cabinet near the electronics (do not ground at the machine/ sensor). The sensor housing is grounded at the machine frame. To prevent interference, the cable length should not exceed 100 m.

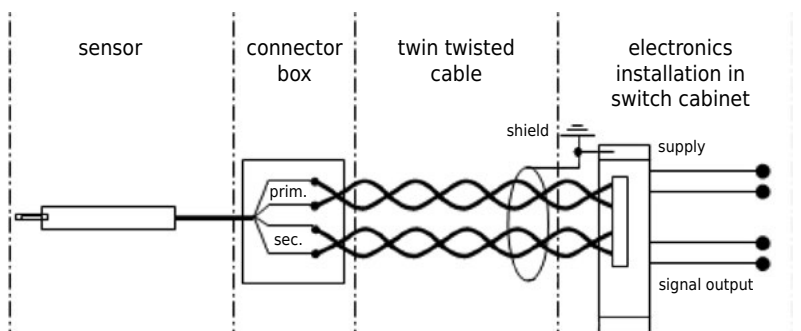

## ADJUSTMENT OF ZERO POINT AND GAIN

Please note that the zero point and gain may shift for long cable length between sensor and electronics. Thus install the sensor with the according cable length to the electronics and then adjust zero point and gain.

1. Push rod entirely in - adjust offset.  
Move the sensor to the zero point of the measuring range and set the offset potentiometer on 4 mA/0 V for the output signal.
2. Push rod entirely out - adjust gain  
Move the sensor to the end of the measuring range (push rod moved out) and set the gain potentiometer on 20 mA /10 V/5 V for the output signal.

Signal inversion:

If an inverted output signal is required (20...4 mA /10...0 V/5...0 V), swap clamps 6 and 8 (secondary coil) on the external electronics.

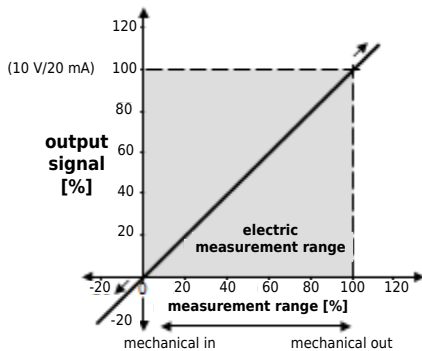

The output signal is referring to the electric measuring range. If the sensor is operated outside the measuring range or the measuring range is exceeded, the signal is also outside the defined range (i.e. > 10 V/20 mA or < 0 V/4 mA, in the graph: > 100 % or < 0 %). Please keep this in mind for control systems with cable break detection lower than 4 mA or for a maximum input voltage > 10 V of measuring instruments. If necessary install the sensor **before** connecting to the PLC.

Running direction of signal: If the push rod is moving into the sensor (e.g. sprung load pushed in), the signal is reducing. If the push rod is moving out, the output signal is increasing. The running direction of the signal can also be inverted.

## CABLE BREAK DETECTION

The electronics by WayCon feature a built-in cable break detection. This is achieved by an impedance measurement of the LVDT's secondary coil. If the sensor cable is cut, the impedance on the secondary connections of the electronics change regardless of the push rod position, triggering the cable break detection. This feature is based on a broken secondary connection. A partial cable break of the primary connections (cables between primary coil and electronics) will not activate this function. The electronics vary in their functional range. The external electronics IMCA offers the widest range. The cable electronics KAB only visualises a cable break by a red LED.

IMCA: For the use of the cable break functions an alarm system (signal lamp, acoustic alarm device) or an alarm input of the PLC must be connected to the 7-pole terminal. The circuit board features a analog switch which is a normally open.

Normal operation IMCA:

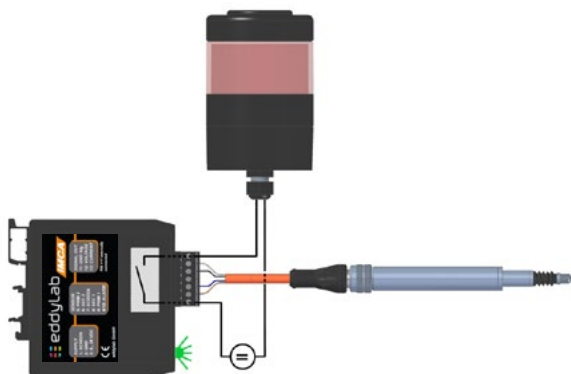

- The green „POWER-LED“ on the front side is on.
- The signal output is active.
- The alarm output is disabled.

Cable break IMCA:

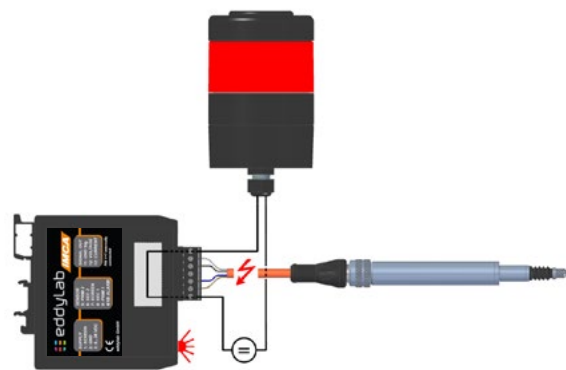

- In case of a cable break the analog switch closes and the alarm system is activated or an electrical signal is conducted. Please note the maximum electrical values: 30 mA or 14 V.
- A front side „ERROR-LED“ flashes in case of an error.
- The signal output is deactivated. There is no current or voltage signal.

Normal operation KAB:



- The green „POWER-LED“ is on.

Cable break KAB:



- The red „ERROR-LED“ is on.

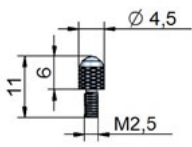
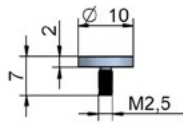
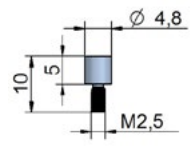
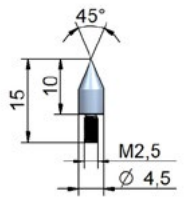
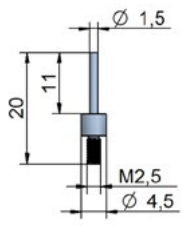
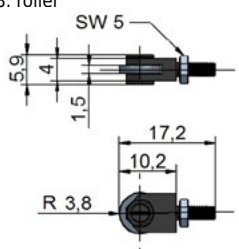

## FEELER FOR SPRING LOADED VERSION

<p>Tastkopf-01, steel (standard) Tastkopf-01-HM, cemented carbide Tastkopf-01-R, ruby Tastkopf-01-K, ceramics</p> 	<p>Tastkopf-02, steel Tastkopf-02-HM, cemented carbide</p> 	<p>Tastkopf-03, steel Tastkopf-03-HM, cemented carbide</p> 
<p>Tastkopf-04, steel</p> 	<p>Tastkopf-05, steel</p> 	<p>Tastkopf-782.238, roller</p> 

### Material of Tastkopf-01 feeler balls:

steel: for standard applications  
 ruby: much harder and wear resistant than steel, non-conductive, for all applications except for measuring on aluminium and cast iron  
 ceramics: comparable to ruby, best choice for measuring on aluminium and cast iron

## MOUNTING PARTS

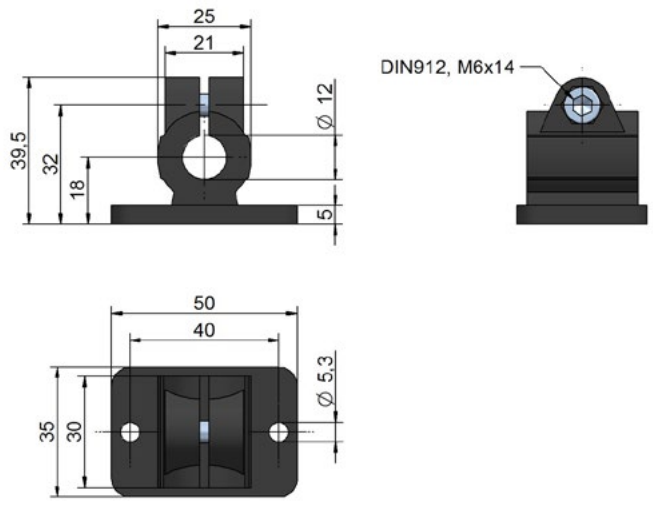
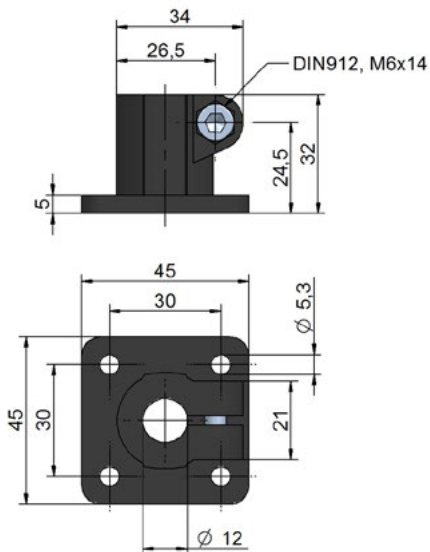
<p><b>Flanschklemmstück 1218: flange clamp <math>\varnothing 12</math> mm for SM-series</b>          material: reinforced polyamide  <math>\varnothing 18</math> mm without reducing bush, <math>\varnothing 12</math> mm with reducing bush (included)</p> 	<p><b>Fußklemmstück 1218: base clamp <math>\varnothing 12</math> mm for SM-series</b>          material: reinforced polyamide  <math>\varnothing 18</math> mm without reducing bush, <math>\varnothing 12</math> mm with reducing bush (included)</p> 
---	--

## ORDER CODE SENSOR

SM - - - -

<b>Measurement range [mm]</b>	
0...2	2
0...5	5
0...10	10
0...25	25
0...50	50
0...100	100
0...200 (not with spring loaded version)	200

<b>Type</b>	
free core (without core extension)	A
push rod unguided	S
push rod guided	SG
spring loaded	T

-	<b>Options</b>
0	sensor without options sensor with options

SA* SR* KA KR	<b>Output</b> (not option H/ IP68) axial connector M12 (not option H/ IP68) radial connector M12 axial cable output radial cable output
------------------------	---

\* please note: connector output in combination with cable electronics KAB: a connection cable K4P.. is necessary.

-	<b>Options</b>
IP68	protection class IP67 (standard) protection class IP68
H	increased working temperature up to 150 °C
H200	increased working temperature up to 200 °C
L20	improved linearity 0.20 %
L10	improved linearity 0.10 %
FB	gaiter (only models with FS up to 0...25 mm)
RO	through hole (only for KR versions)
W	shaft seal

## ORDER CODE ELECTRONICS

External electronics (DIN-rail mounting)	IMCA	- - - -	020A 420A 10V 5V ±5V ±10V	<b>Output</b> 0...20 mA 4...20 mA 0...10 V 0...5 V ± 5 V ± 10 V
Cable electronics	KAB			
<b>Voltage supply</b>				
24 VDC	24V			

## ACCESSORIES

### Connection cable with M12 connector

K4P2M-S-M12	2 m, straight connector
K4P5M-S-M12	5 m, straight connector
K4P10M-S-M12	10 m, straight connector
K4P2M-SW-M12	2 m, angular connector
K4P5M-SW-M12	5 m, angular connector
K4P10M-SW-M12	10 m, angular connector

### Additional cable (2 m length is standard)

Kabel-TPE	order code for 1 m of additional TPE cable
Kabel-PTFE-UL	order code for 1 m of additional PTFE cable

### Mating connector (for self assembly)

D4-G-M12-S	straight, M12 for self assembly (shielded)
D4-W-M12-S	angular, M12 for self assembly (shielded)

### Feeler

Tastkopf-01
Tastkopf-01-HM
Tastkopf-01-R
Tastkopf-01-K
Tastkopf-02
Tastkopf-02-HM
Tastkopf-03
Tastkopf-03-HM
Tastkopf-04
Tastkopf-05
Tastkopf-782.238 (roller)

### Mounting parts

Flanschklemmstück 1218
Fußklemmstück 1218
Retrofit kit gaiter SM2 / SM5 / SM10 / SM25

Subject to change without prior notice.