

# LVDT EXTERNAL ELECTRONICS



## IMCA External electronics

connection and signal adjustment

### Content

## TECHNICAL DATA

### IMCA Electronics

output signal	0...20 mA, 4...20 mA (load <300 Ohm) 0...5 V, ± 5 V (load >5 kOhm) 0...10 V, ± 10 V (load >10 kOhm)
temperature coefficient	zero 150 ppm/ °C, max. value 400 ppm/ °C
ripple	< 0.5 mV <sub>eff</sub> up to 300 Hz, < 4 mV <sub>eff</sub> up to 20 MHz
max. frequency	300 Hz/ -3 dB (6-pole Bessel)
isolation stability	> 1000 VDC
power supply	9...36 VDC
current consumption	75 mA at 24 VDC 150 mA at 12 VDC
sensor supply	3 V <sub>eff</sub> 3 kHz (adjustable, 1-18 kHz)
working temperature	-40...+85 °C
storage temperature	-40...+85 °C
housing	polyamide PA6.6, meets UL94-V0
mounting	on DIN EN-rail

The output signal is referring to the electric measuring range. If the sensor is operated outside the measuring range or the measuring range is exceeded, the signal will also be outside the defined range (i.e. > 10 V/ 20 mA or < 0 V/ 4 mA, in the graph: > 100 % or < 0 %). Please keep this in mind for control systems with cable break detection lower than 4 mA or for a maximum input voltage > 10 V of measuring instruments. If necessary install the sensor **before** connecting to the PLC.

Running direction of signal: If the push rod is moving into the sensor (e.g. spring loaded version pushed in), the signal will decrease. If the push rod is moving out, the output signal will increase. The running direction of the signal can also be inverted.

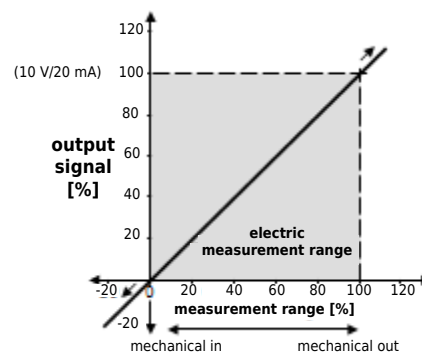

## ELECTRICAL CONNECTION

damp	connection	function	wire color	
			standard TPE-cable, orange	PTFE-cable (H-option), white
1	power	earth		
2		GND power		
3		power 9...36 VDC		
4	sensor	n. c.		
5		primary coil 2	white	white
6		secondary coil 2	black	green
7		shield		
8		secondary coil 1	blue	brown
9		primary coil 1	brown	yellow
10	signal	n. c.		
11		GND signal		
12		voltage output		
13		current output		

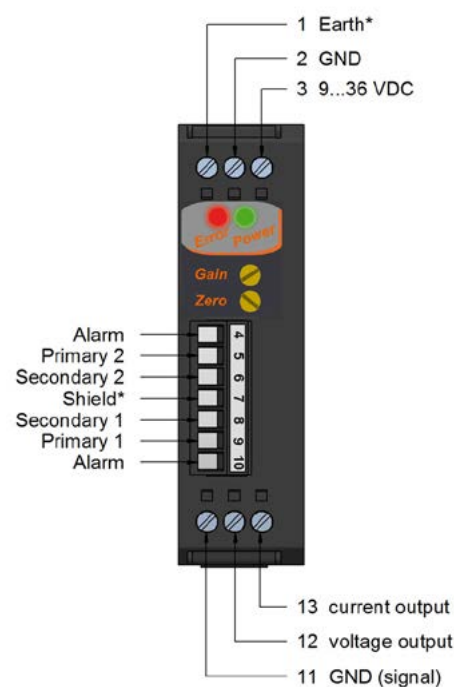

## CABLE BREAK DETECTION

The electronics by WayCon feature a built-in cable break detection and offers a wide range of functions. This is achieved by an impedance measurement of the LVDT's secondary coil. If the sensor cable is cut, the impedance of the secondary connections change regardless of the push rod position, triggering the cable break detection. This feature is based on a broken secondary connection. A partial cable break of the primary connections (cables between primary coil and electronics) will not activate this function.

For the use of the cable break functions an alarm system (signal lamp, acoustic alarm device) or an alarm input of the PLC must be connected to the 7-pole terminal. The circuit board features an analogue switch which is normally open.

Normal operation:

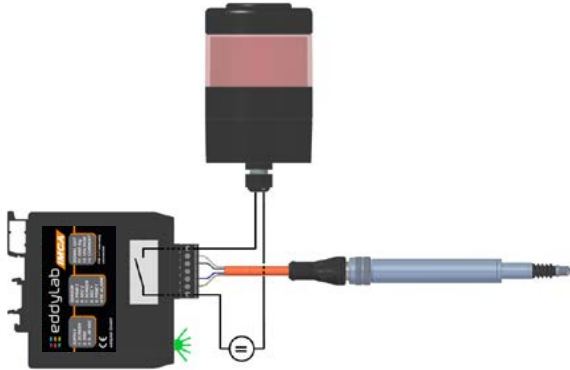

- The green „POWER-LED“ on the front side is on.
- The signal output is active.
- The alarm output is disabled.

Cable break:

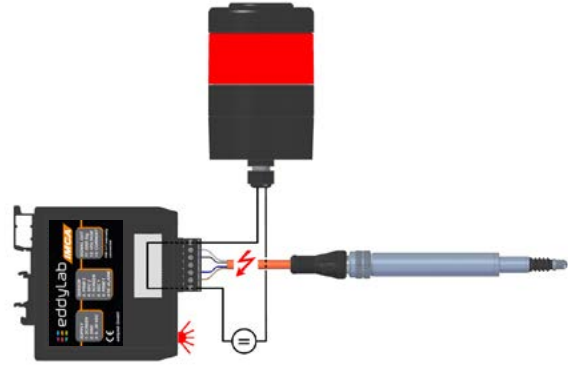

- In case of a cable break the analogue switch closes and the alarm system is activated or an electrical signal is conducted. Please note the maximum electrical values: 30 mA or 14 V.
- A front side „ERROR-LED“ flashes in case of an error.
- The signal output is deactivated. There is no current or voltage signal.

## OPENING OF HOUSING COVER

The housing can be opened by drawing the cover lid at the marked positions. Usually this can be done by hand.

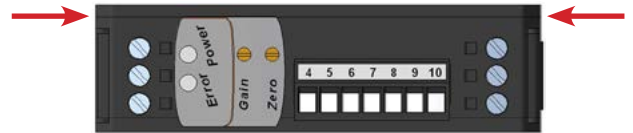

## SETTING THE OUTPUT SIGNAL

Signal	solder jumper		
	SJ1	SJ2	SJ3
0...10 V	■	■	
4...20 mA	■	■	
0...20 mA	■	■	
0...5 V	■	■	■
±5 V		■	
±10 V			

**CAUTION:**  
A readjustment must be done after changing the output signal. Please follow the instructions on page 5

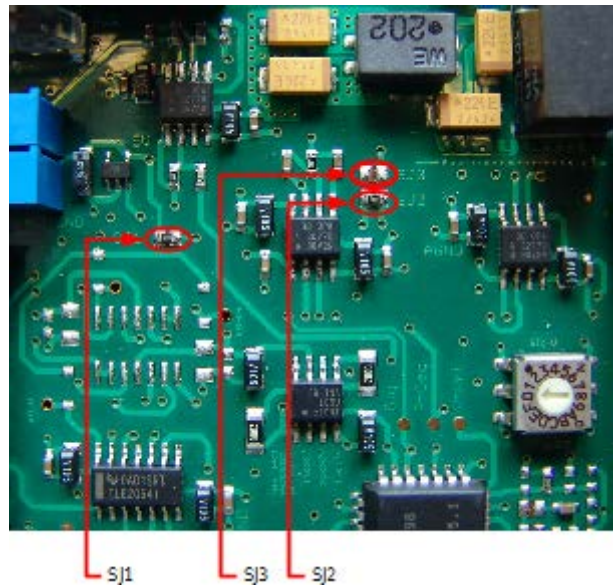

## ADJUSTMENT OF THE PHASE SHIFT AND GAIN

An adjustment of the phase shift is necessary for most sensors to achieve best linearity. Please open the top cover of the IMCA housing.

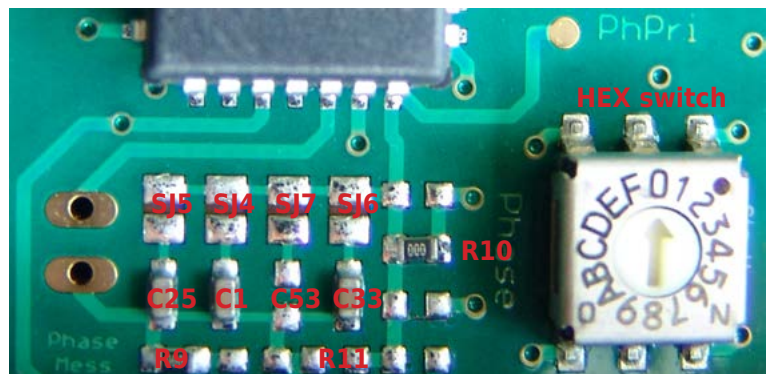
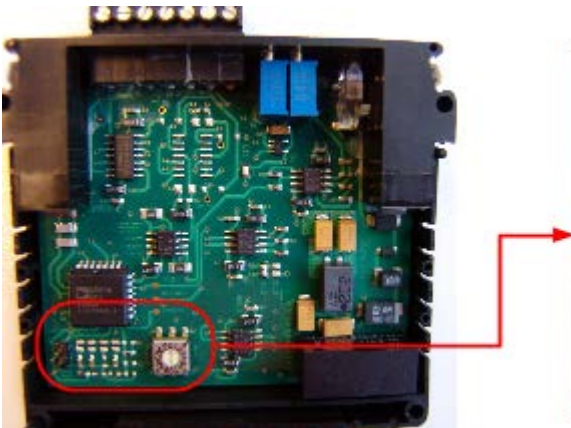

### Activating phase shift:

1. Remove the resistors R9 and R10
2. Solder 1 kOhm resistors 0603 on R9 and R10
3. Solder 100 kOhm resistor 0603 on R11
4. Solder bridges on SJ4, SJ5, SJ6 and SJ7 activate the capacitors C25, C1, C53 and C33. Please ask WayCon Engineering which capacitors must be activated for your sensor type. E.g. SM25(-HYD) requires SJ4, SJ5 and SJ6.

### Setting the gain:

A coarse setting of the gain must be done by turning the HEX switch into the right position. The gain is decreasing by turning the HEX clockwise, starting from position „0“. Turn the HEX until the output signal shows roughly 0...10 V (or 4...20 mA). Please refer to the next page for the fine setting of gain and offset.

## ADJUSTMENT OF THE OUTPUT SIGNAL

### Note:

WayCon always aims for best linearity when calibrating the sensor and electronics before shipping. Due to small differences in the electric characteristics of the coils inside the LVDTs, the start-point of the measurement range may vary slightly. Please refer to the following figures to find the exact start of the measurement range of your sensor.

Please note that the zero point and gain may shift due to long cable lengths between sensor and electronics. Therefore please connect the sensor with the according cable length to the electronics first and then adjust zero point and gain.

We recommend to use gauge blocks for max. precision to put the push rod into a specific position. Alternatively a caliper can also be used.

1. Move sensor into start position:

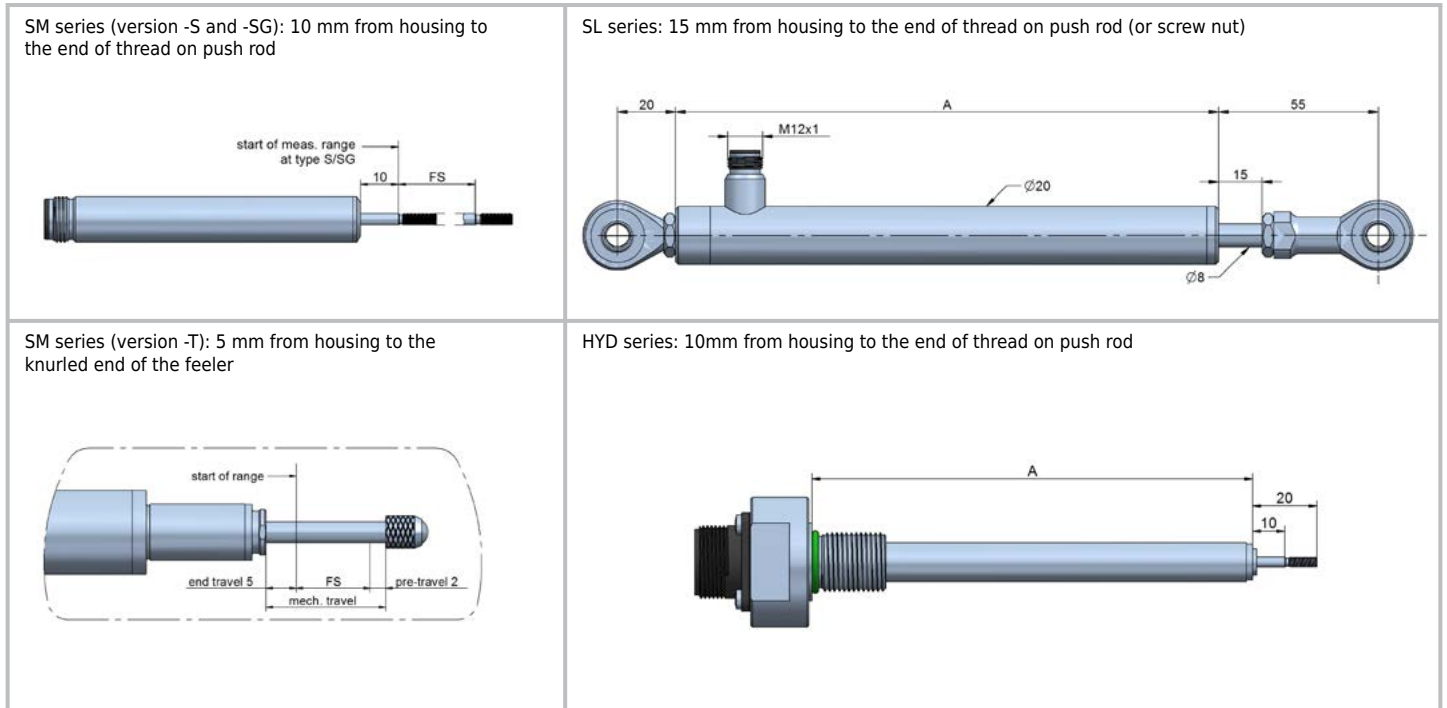

2. Adjust offset: Use the offset potentiometer to set the output signal to 4.000 mA (for 4...20 mA) or 0.000 V (for 0...10 V).

3. Move the push rod to the end of the measurement range:

- e. g. SM25-T: distance between sensor and feeler 30 mm (5 + 25 mm)
- e. g. SL100-G: distance between sensor and screw nut must be 115 mm (15 + 100 mm)

4. Adjust gain: Use the gain potentiometer to set the output signal to 20.000 mA or 10.000 V.

5. Final check: Please reassure that the output signal is still correct at the end and start of the range. Repeat steps 2-4 if there are slight deviations.

### Note:

output signal 0...20 mA: adjustment according to 4...20 mA

output signal 0...5 V: adjustment according to 0...10 V

output signal  $\pm 5$  V,  $\pm 10$  V: Move the push rod to the middle of the measurement range (SM25-T: 17.5 mm, SL100-G: 65 mm). Set the offset to 0.000 V. Move the sensor to start and end of the measurement range and check, if the output signal shows the same value (e. g. -10.035 V and +10.035 V). If not, please adjust by turning the offset potentiometer. Finally set the gain to 5,000 V (-5 V) or 10,000 V (-10 V).

### Signal inversion:

If an inverted output signal is required (20...4 mA/ 10...0 V/ 5...0 V), swap clamps „Sec +“ and „Sec -“ (secondary coil) on the circuit board of the cable electronics.



Subject to change without prior notice.