

# LASER

## Laser-Position-Transducer

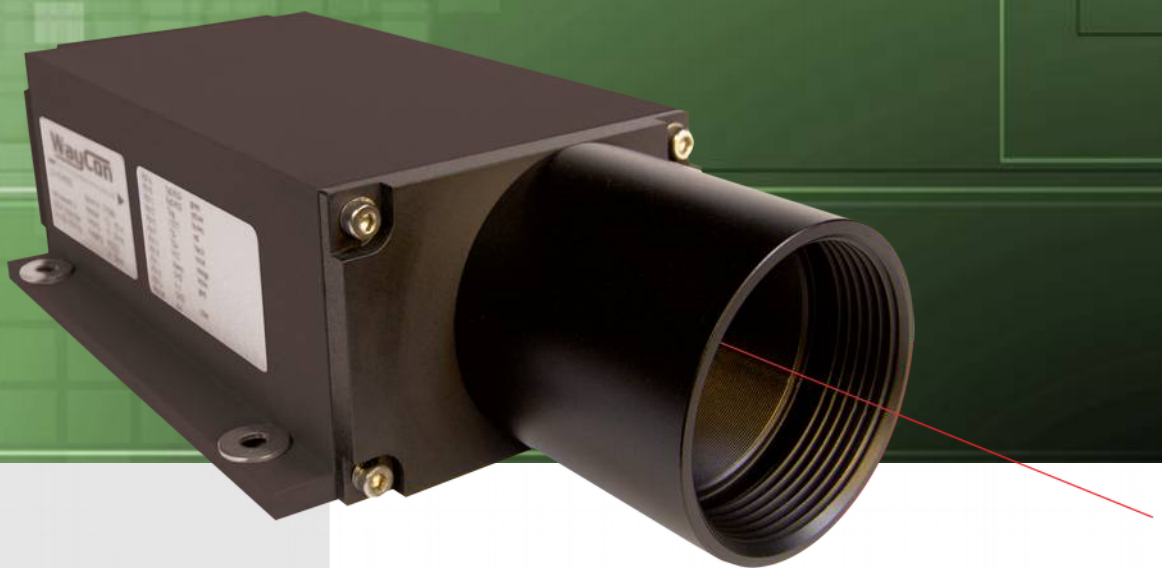

### Content:

<b>Technical Data</b>	<b>....2</b>
<b>Technical Drawings</b>	<b>....2</b>
<b>Types Of Output</b>	<b>....3</b>
<b>Configuration Software</b>	<b>....4</b>
<b>Order Code</b>	<b>....5</b>
<b>Options &amp; Accessories</b>	<b>....5</b>

### LLD Series

#### Key-Features:

- Measurement range: 0.1 to 150 m
- Resolution: 0.1 mm
- Repeatability:  $\pm 0.5$  mm
- Linearity:  $\pm 2$  mm on white surfaces,  $\pm 3$  mm on natural surfaces
- Protection class: IP65
- Working temperature: -10 to 50 °C, with heating: -40 to 50 °C
- Measuring frequency selectable: 10Hz or 50Hz
- Analog output: 4..20mA (must be configured with the included software)
- Digital outputs: RS232, RS422, Profibus, SSI

## TECHNICAL DATA

Measurement range	0.1...30 m on all natural diffuse reflecting surfaces, on target board up to 150 m
Resolution	0.1 mm
Linearity	±2 mm on white surfaces (+15...+30 °C), ±3 mm on natural surfaces (+15...+30 °C), ±5 mm (-10...+50 °C)
Repeatability	≤0.5 mm
Selectable measuring frequency	10 Hz or 50 Hz
Measuring rate	0.16...6 s (10 Hz), 0.02 s (50 Hz)
Supply voltage	10...30 VDC
Max. power consumption	1.5 W, Profibus: 3.2 W
Max. power consumption, option H	24 W (24 VDC), Profibus, SSI: 25.7 W (24 VDC)
Analog output	4...20 mA ( parameterise using RS232/ RS422), load ≤500 Ohm
Digital Output	RS232, RS422, Profibus, SSI
Transfer rate	2,4 / 4,8 / 9,6 / 19,2 / 38,4 kBaud for RS232 and RS422, max. 12 MBaud for Profibus, 50...1000 kHz for SSI
Switching outputs	1 (max. capacity load 0.5 A), Profibus, SSI: 2 (max. capacity load 0.5 A)
Trigger input *	trigger impulse 24 V
Connection	12-pole M16-connector; for Profibus, SSI in addition: 5-pole M12-connector (male) and M12-connector (female)
Light source	laser diode (red), wavelength 650 nm
Laser class	2, ≤1 mW
Protection class	IP65
Storage temperature	-40...+70 °C
Working temperature	-10...+50 °C
Working temperature, option H	-40...+50 °C, by heating
Weight	760 g, Profibus, SSI: 770 g
Electromagnetic compatibility (EMC)	EN 61326-1

\* not available for models with option H (heating)

## TECHNICAL DRAWINGS

LLD-150-RS232, LLD-150-RS422

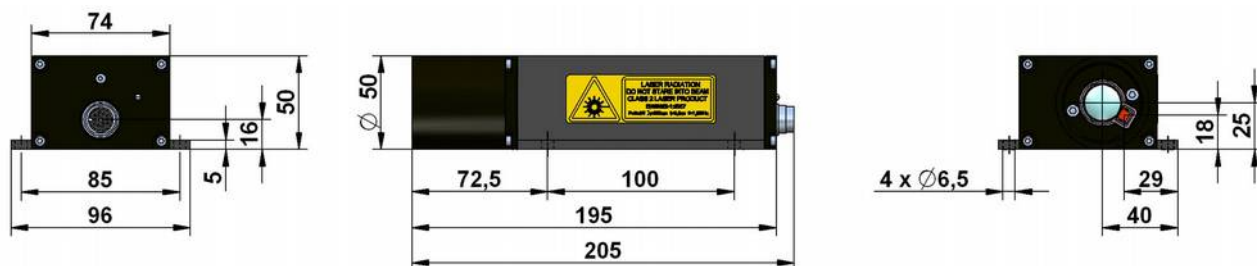

LLD-150-Profibus

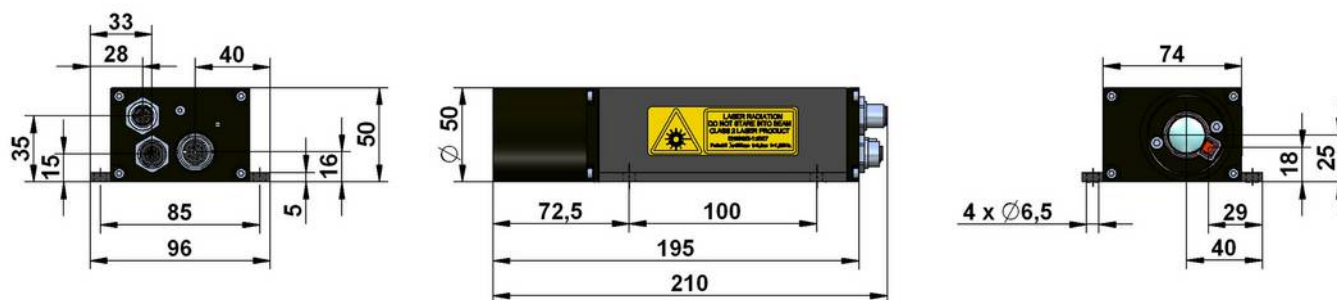

## GETTING STARTED

For initial operation, the sensor has to be set into operation mode, i.e. the autostart function must be configured. This function decides on the mode generally to be activated after switching on. Single point and continuous measurement (distance tracking) in different modes are available. Before using the analog output, the measurement range must be scaled: 4 mA is assigned to the minimum, 20 mA to the maximum measurement range. All these settings are quickly performed by means of the WayCon configuration software included in the delivery.

## DIFFERENT TYPES OF OUPUT

### Analog output 4...20 mA

The analog output allows for transmission of the results by an analog 4...20 mA signal.

The current of the line is proportional to the detected distance.

The measurement range must be scaled during initial operation.

Connector 12-pole, M16

### RS232 output

This classical low-price interface for short distances between sensor and PC/control-system/display is ideally suited to laboratory and PC applications.

Data rate 38.4 kBaud max.

Connector 12-pole, M16

### RS422 output

Differential interface with RS232 protocol, i.e. the data is transmitted by RS232, just that RXD and TXD are transmitted differential on RS422 basis.

Optimized for environment with background noise and long lines (up to 100 m).

Since standard PC's generally do not offer an RS422 interface, this type of communication requires an RS422 interface card or a converter RS422-to- RS232.

Data rate 38.4 kBaud max.

Connector 12pole, M16

### Profibus output

Plug-and-play interface for fieldbus applications.

Configuration by Profibus firmware data file (gsd file), available at [www.waycon.de](http://www.waycon.de)

Data rate 12 Mbaud max.

Connector: 1x 12-pole, M16, 2x 5-pole M12

### SSI output

Synchronous interface for industrial applications.

24 bit, Gray-coded, 1 MHz max.

Connector: 1x 12-pole, M16, 2x 5-pole M12

### Digital switching output

This output allows for supervision of the targets, e.g. with respect to the excess of preset thresholds. A corresponding measurement window must be parametrized beforehand, which determines the beginning and the end of the monitored range. The desired switching point can be set inside this range. The details are discussed in a separate manual included in the delivery.

### Trigger input (not for models with heating)

A distance measurement can also externally be initiated by a signal (voltage pulse 3..24 V), transmitted via trigger input. The user has to configure the desired delay as well as the pulse edge for triggering. All details are described in the manual included in the delivery.

## INCLUDED IN DELIVERY

- LLD sensor
- Manual
- WayCon CD with LLD-configuration software „LLD-communication & data acquisition“

## CONFIGURATION-SOFTWARE

Before starting to work with the LLD-Sensor, the user has to select the operational mode, either via a terminal program like „Hyperterminal“ (WinXP), normally included in a Win32 operating system, or by performing the configuration by means of the conveniently designed user interface of the WayCon software, available in English language.

The latter choice uses the serial interface and is therefore possible only for the RS232 or RS422 LLD-Laser sensors, (not for the Profibus, SSI version). Please be aware that normal PC's and Laptops do not have a RS422 interface and hence a RS422/RS232 converter is required. When establishing the connection, the distance between converter and PC (RS232 line) should be kept as short as possible. The possibly long and EMI (electromagnetic interference) loaded distance between converter and LLD-sensor thus represents the RS422 line.

The parameters shown in the graphic user interface correspond to the parameters described in the manual of the sensor. For stand-alone operation (i.e. without connection to a PC or a PLC), essential parameters are Autostart and Analog Range Begin/End, used to configure the sensor for instantaneous automatic selection of the measurement mode after switching on.

The WayCon Configuration Software furthermore offers the possibility to save measured distances in ASCII format by means of a data logger.

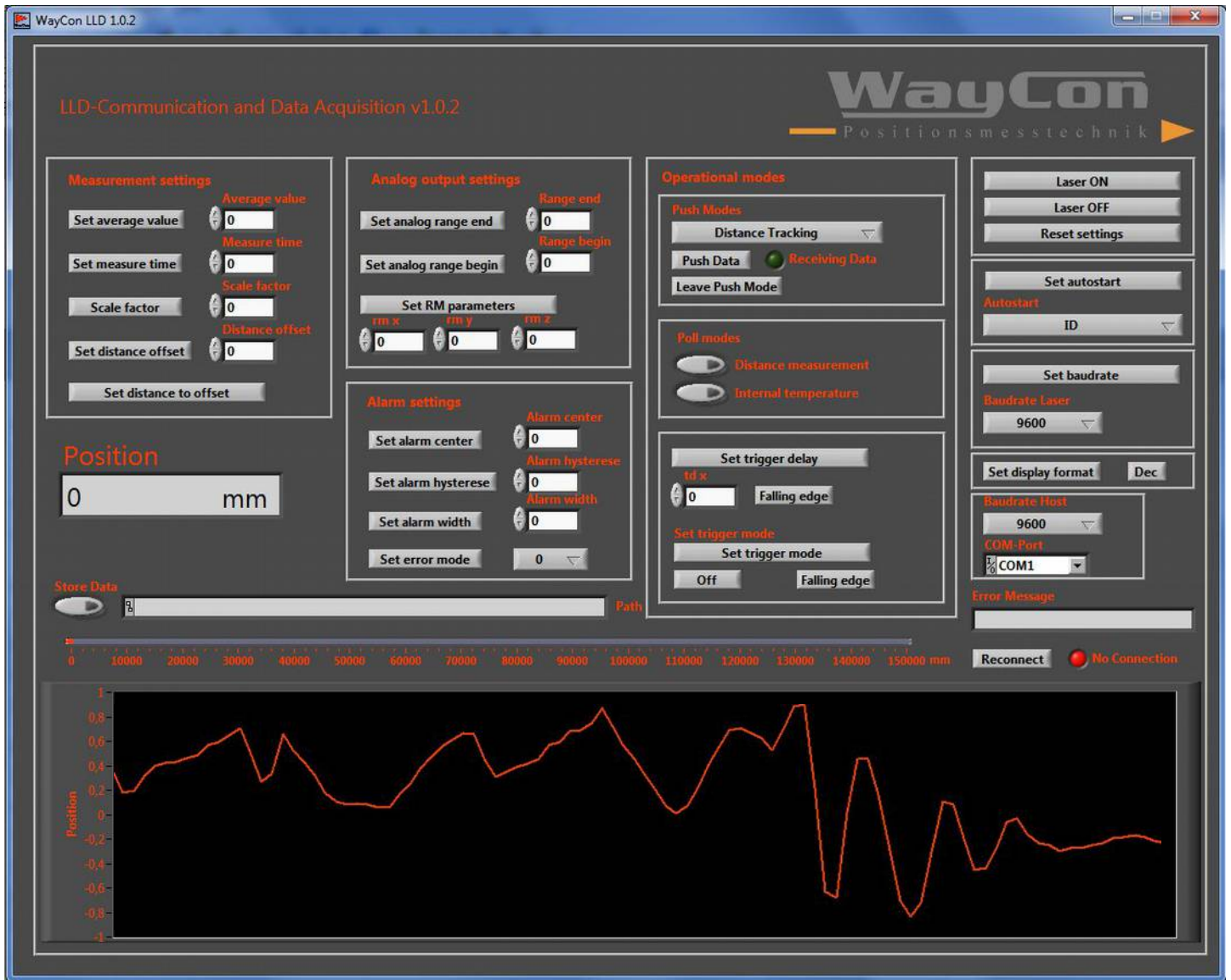

## CONFIGURATION-SOFTWARE

As described above the LLD-Sensor has to be switched into the operational mode, before measurements can be made. WayCon offers the possibility for the RS232- and RS422-based laser sensors to make a pre-configuration. In this case the desired measurement range is required, e.g. 5 m measurement range begin, 25 m measurement range end. After this configuration by WayCon 4 mA will be the output at the measurement range begin and 20 mA at the measurement range end. The laser sensor can then be used right after unpacking, without any additional adjustments.

## ORDER CODE

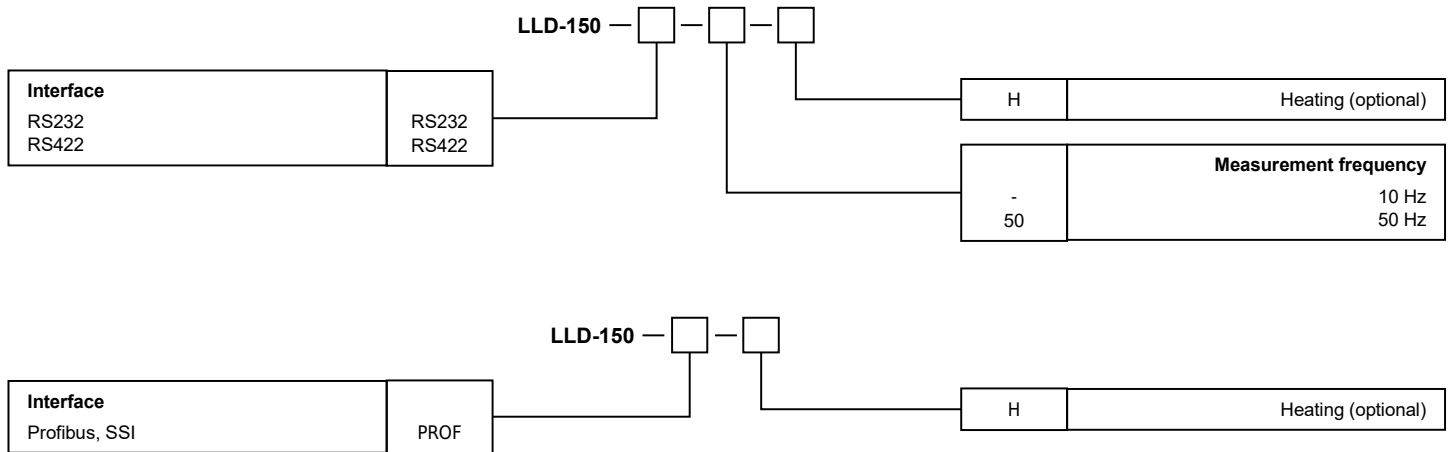

## OPTIONS AND ACCESSORIES

### Accessories RS232 / RS422

KAB-LLD-2M	Interface cable 2 m
KAB-LLD-5M	Interface cable 5 m
KAB-LLD-10M	Interface cable 10 m
94477	Mating connector M16, straight
LLD Aktivierung	Pre-configuration by WayCon for RS232, RS422 models

### Option for all models

H	Heating
---	---------

### Target Board (for measurement distances 30 m and greater)

ZT51_WEISS	Target board for Laser Type LLD
------------	---------------------------------

### Accessories Profibus

KAB-LLD500-2M-S	Interface cable 2 m, supply
KAB-LLD500-5M-S	Interface cable 5 m, supply
KAB-LLD500-10M-S	Interface cable 10 m, supply
KAB-LLD500-2M-SW	Interface cable 2 m, angular connector
KAB-LLD500-5M-SW	Interface cable 5 m, angular connector
KAB-LLD500-10M-SW	Interface cable 10 m, angular connector
94133	Profibus OUT M12 connector, male
94136	Profibus IN M12 connector, female
94145	Profibus M12 terminating resistance
K5P2M-B-M12-PROF	Cable 2 m, female connector 5-pol. M12, open ends
K5P2M-SB-M12-PROF	Cable 2 m, female 5-pol. M12, male 5-pol. M12
K5P2M-B-M12-PROF	Cable 2 m, male connector 5-pol. M12, open ends
K5P5M-B-M12-PROF	Cable 5 m, female connector 5-pol. M12, open ends
K5P5M-SB-M12-PROF	Cable 5 m, female 5-pol. M12, male 5-pol. M12
K5P5M-S-M12-PROF	Cable 5 m, male connector 5-pol. M12, open ends
K5P10M-B-M12-PROF	Cable 10 m, female connector 5-pol. M12, open ends
K5P10M-SB-M12-PROF	Cable 10 m, female 5-pol. M12, male 5-pol. M12
K5P10M-S-M12-PROF	Cable 10 m, male connector 5-pol. M12, open ends



### General safety instructions

Attention radiation laser.

Do not stare into beam.

Do not point the laser beam towards someone's eye.

It is recommended to stop the beam by a matte object or matte metal shield.

Laser regulations require the power to the sensor be switched off when turning off the whole system this sensor is part off.

Subject to change without prior notice.

**WayCon Positionsmesstechnik GmbH**

email: [info@waycon.de](mailto:info@waycon.de)

internet: [www.waycon.biz](http://www.waycon.biz)

**Head Office**

Mehlbeerenstr. 4

82024 Taufkirchen

Tel. +49 (0)89 67 97 13-0

Fax +49 (0)89 67 97 13-250

**Office Köln**

Auf der Pehle 1

50321 Brühl

Tel. +49 (0)2232 56 79 44

Fax +49 (0)2232 56 79 45