

# MAGNESCALE

digital magnetic scale



## Serie SL110, SL130, PL20C

Key-Features:

- SL110: Profile scale, extreme robust
- SL130: flexible magnetic tape scale to glue on
- available ranges SL110: 200 to 2000 mm
- available ranges SL130: 200 to 30.000 mm
- Resolution 10  $\mu\text{m}$
- Linearity up to  $\pm 25 \mu\text{m}$
- Output signal PL20C: A/B quadrature signal
- Displacement speed up to 300 m/min
- Working temperature 0...+45 °C
- Protection class PL20C: IP67
- resistant against dirt, water, oil, vibrations and shock

**Content:**

## TECHNICAL DATA SL110

Model		
Measurement range MR	[mm]	200 / 300 / 400 / 500 / 600 / 700 / 800 / 1000 / 1200 / 1500 / 1600 / 1700 / 1800 / 2000
Resolution (20°C)	[μm]	10
Linearity (20°C)	[μm]	±(25 + 5MB/1000)
Reference point		none
Working temperature	[°C]	0 to 45
Storage temperature	[°C]	-20 to 50
Displacement speed	[m/min]	maximum 300
Expansion coefficient		(11.1 ±1) x 10 <sup>-6</sup> /°C
Total length	[mm]	MB + 103
Reading head		PL20C

## TECHNICAL DATA SL130

Model		
Measurement range MR	[mm]	200/ 300/ 400/ 500/ 1000/ 1200/ 1500/ 1600/ 1700/ 1800/ 2000/ 2500/ 3000/ 4000/ 5000/ 6000/ 7000/ 8000/ 9000/ 10000/ 20000/ 30000
Resolution (20°C)	[μm]	10
Linearity (20°C)	[μm]	MB ≤7000 mm: ±(25 + 5MB/1000) / MB ≥8000 mm: ±(25 + 5MB/1000 + 10N*)
Reference point		none
Working temperature	[°C]	0 to 45
Storage temperature	[°C]	-20 to 50
Displacement speed	[m/min]	maximum 300
Expansion coefficient		(10,4 ±1) x 10 <sup>-6</sup> /°C
Total length	[mm]	MB + 100
Reading head		PL20C

\* MB ≤10000: N=1 / MB =20000: N=1 / MB =30000: N=3

## TECHNICAL DATA PL20C

Model		PL20C-3/-3C	PL20C-5/-5C	PL20C-10/-10C	PL20C-15/-15C	PL20C-20/-20C	PL20C-30
Cable length	[m]	3	5	10	15	20	30
Resolution (20°C)	[μm]	10					
Output signal	[μm]	A/B quadrature signal					
Screw tightening torque		0.7 bis 1.1 Nm					
Working temperature	[°C]	0 to 45					
Storage temperature	[°C]	-20 to 50					
Displacement speed	[m/min]	maximum 300 (varies with the settings)					
Distance reading head - magnetic tape	[mm]	maximum 1.5 (contactless)					
Bending radius cable	[mm]	minimum 100					
Compatible Displays		LG20 / LH70 / LH71 / LH72 / LY71 / LY72					

# TECHNICAL DRAWING SL110

Scale

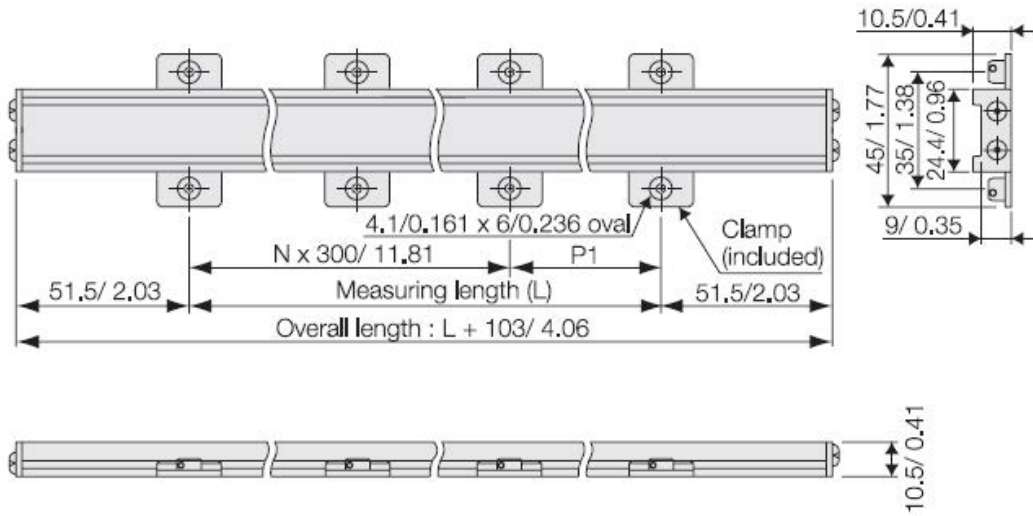

Model	Length	N	P1	Number of clamps
SL110-20	200	0	200	4
SL110-30	300	1	0	4
SL110-40	400	1	100	6
SL110-50	500	1	200	6
SL110-60	600	2	0	6
SL110-70	700	2	100	8
SL110-80	800	2	200	8
SL110-100	1000	3	100	10
SL110-120	1200	4	0	10
SL110-150	1500	5	0	13
SL110-160	1600	5	100	14
SL110-170	1700	5	200	14
SL110-180	1800	6	0	14
SL110-200	2000	6	200	16

# TECHNICAL DRAWING SL130

Scale

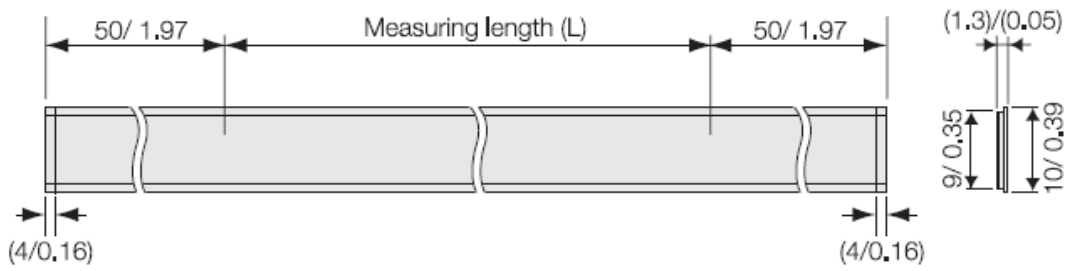

Model	Range	Total length
SL130-20	200	300
SL130-30	300	400
SL130-40	400	500
SL130-50	500	600
SL130-60	600	700
SL130-70	700	800
SL130-80	800	900
SL130-100	1000	1100
SL130-120	1200	1300
SL130-150	1500	1600
SL130-160	1600	1700
SL130-170	1700	1800
SL130-180	1800	1900
SL130-200	2000	2100
SL130-250	2500	2600
SL130-300	3000	3100
SL130-400	4000	4100
SL130-500	5000	5100
SL130-600	6000	6100
SL130-700	7000	7100
SL130-800	8000	8100

# TECHNICAL DRAWING PL20C

## Reading head PL20-...C (metal armoured hose)

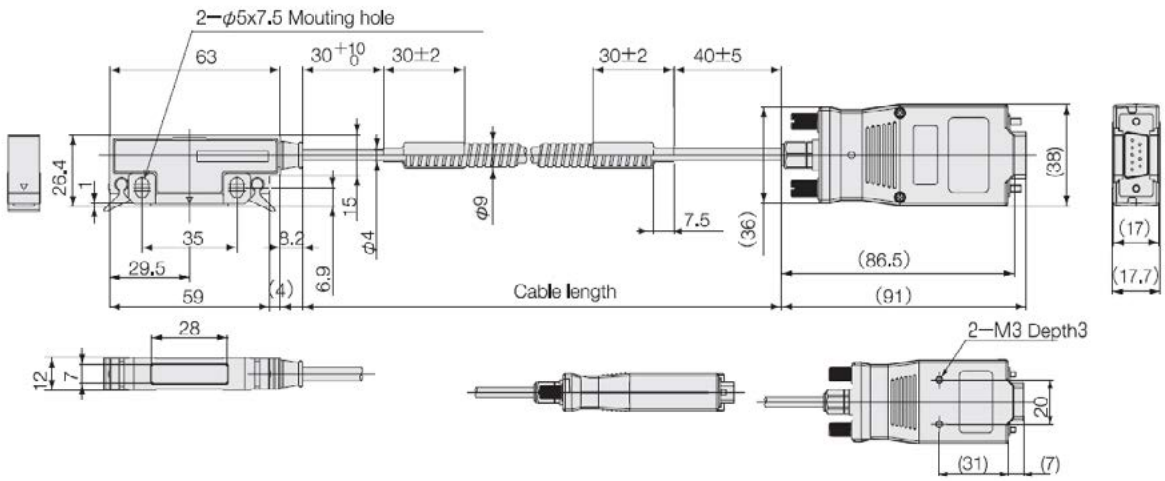

## Reading head PL20C...

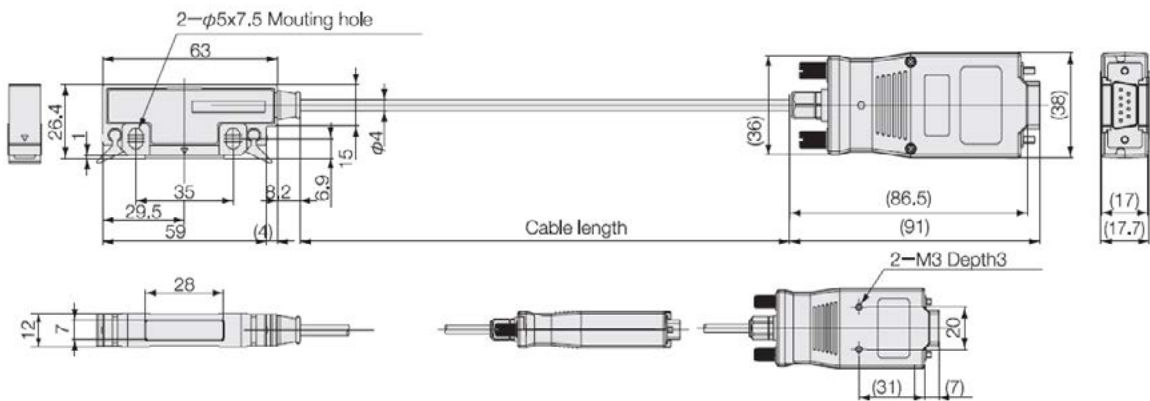

### Head clearance

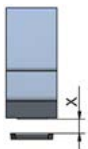

Distance X      1.5 mm or less

### Track deviation



### Inclination angle

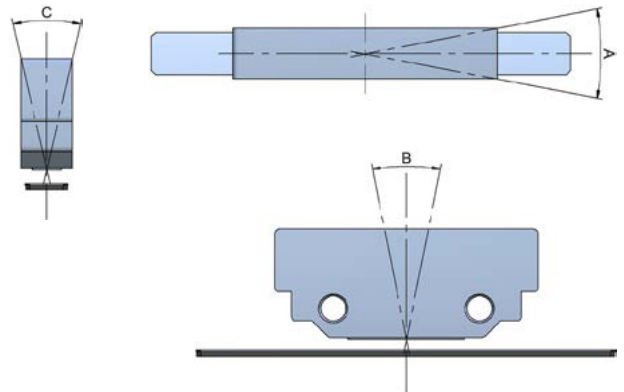

**A**      **B**      **C**  
 $\pm 3^\circ$  or less       $\pm 0,5^\circ$  or less       $\pm 3^\circ$  or less

# DISPLAYS MAGNESCALE

## LG20:

General purpose display. The LG20 offers a Reset/Preset function

## LH70 Serie:

High performance counter for Mille (LH70/LH71) and Lathe (LH70-3/ LH71-3) applications.

## LH71A-3

Can be user for milling machines and lathes applications by switching initial settings.

## LH72

Designed especially for lathes.



### Overview Magnescale Series

	LG20	LH70/LH71	LH72
Display axes	1, 2, 3		3
Display	7 digits, orange LEDs, floating minus sign		
Display resolution	0,1 / 0,5 / 1 / 5 / 10 µm	0,1 / 0,5 / 1 / 5 / 10 µm	
	1 s / 10 s / 1 min / 10 min		
Input signal	TTL Line driver RS422		
Power supply	12 VDC using separate power supply unit PSC23 with 100 - 240 VAC		
Weight	1.5 kg		

### Functions of the displays

	LG20	LH70	LH71	LH71A	LH72
Reset	■	■	■	■	■
Preset	■	■	■	■	■
Absolute/Incremental		■	■	■	■
Diameter display	■	■	■	■	■
Angle display		■	■	■	■
Alarm display	■	■	■	■	■
Zero point detection		■	■	■	■
Datum points		10	150	150	
Tool memory *		12	99	99	99
Midpoint calculation		■	■	■	■
Scaling			■	■	■
Addition function *		■	■	■	■
Programming function			■	■	■
Bolt hole circle		■	■	■	
Line hole			■	■	
Simple R cutting		■	■	■	
Linearity error compensation	■	■	■	■	■
Segment error compensation			■	■	■
Data storage	■	■	■	■	■
Energy saving function	■	■	■	■	■
Navigation function		■	■	■	■
External reset				■	■
Touch sensor function				■	

\* only 3-axes display

## ORDER CODE MAGNETIC TAPE MAGNESCALE

SL110-20	Measurement range 200 mm
SL110-30	Measurement range 300 mm
SL110-40	Measurement range 400 mm
SL110-50	Measurement range 500 mm
SL110-60	Measurement range 600 mm
SL110-70	Measurement range 700 mm
SL110-80	Measurement range 800 mm
SL110-100	Measurement range 1000 mm
SL110-120	Measurement range 1200 mm
SL110-150	Measurement range 1500 mm
SL110-160	Measurement range 1600 mm
SL110-170	Measurement range 1700 mm
SL110-180	Measurement range 1800 mm
SL110-200	Measurement range 2000 mm

SL130-20	Measurement range 200 mm
SL130-30	Measurement range 300 mm
SL130-40	Measurement range 400 mm
SL130-50	Measurement range 500 mm
SL130-60	Measurement range 600 mm
SL130-70	Measurement range 700 mm
SL130-80	Measurement range 800 mm
SL130-100	Measurement range 1000 mm
SL130-120	Measurement range 1200 mm
SL130-150	Measurement range 1500 mm
SL130-160	Measurement range 1600 mm
SL130-170	Measurement range 1700 mm
SL130-180	Measurement range 1800 mm
SL130-200	Measurement range 2000 mm
SL130-250	Measurement range 2500 mm
SL130-300	Measurement range 3000 mm
SL130-400	Measurement range 4000 mm
SL130-500	Measurement range 5000 mm
SL130-600	Measurement range 6000 mm
SL130-700	Measurement range 7000 mm
SL130-800	Measurement range 8000 mm
SL130-900	Measurement range 9000 mm
SL130-1000	Measurement range 10.000 mm
SL130-2000	Measurement range 20.000 mm
SL130-3000	Measurement range 30.000 mm

## ORDER CODE READING HEAD MAGNESCALE

PL20C-3	Cable length 3 m
PL20C-5	Cable length 5 m
PL20C-10	Cable length 10 m
PL20C-15	Cable length 15 m
PL20C-20	Cable length 20 m

PL20C-3C	Cable length 3 m, metal armoured hose
PL20C-5C	Cable length 5 m, metal armoured hose
PL20C-10C	Cable length 10 m, metal armoured hose
PL20C-15C	Cable length 15 m, metal armoured hose
PL20C-20C	Cable length 20 m, metal armoured hose

## DISPLAYS

Display	
LG20-1	Digital display 1 axis
LG20-2	Digital display 2 axes
LG20-3	Digital display 3 axes
LH70-1	High performance display 1 axis
LH70-2	High performance display 2 axes
LH70-3	High performance display 3 axes
LH71-1	High performance display 1 axis
LH71-2	High performance display 2 axes

LH71-3	High performance display 3 axes
LH71A	High performance display 3 axes
LH72-3	High performance display 3 axes
LY71	2 channel multifunctional Display
LY72	2 channel multifunctional Display, RS232C

### Power supply unit for display

PSC23	Power supply unit
-------	-------------------





Subject to change without prior notice.