

# LVDT

## Inductive Position Transducer - Hydraulic Series



### SM-HYD-F18 Hydraulic-Series

#### Key-Features:

- M18x1,5 mm integral thread
- Operating pressure 150 bar
- Ranges 2...200 mm
- Linearity up to  $\pm 0.10$  % of full scale
- Protection class IP67 or IP68
- Max. temperature up to +200 °C
- High EMC-grade
- Customised versions available

#### Content:

## INTRODUCTION

LVDTs (Linear Variable Differential Transformers) are inductive sensors excellent for use in harsh industrial environments, e.g. high temperature- and pressure applications, as well as high accelerations and measuring cycles.

The SM series offers ultimate reliability and precision in a small size and is designed for industrial- and lab use. This series is a pressurized hydraulic model to 150 bar for installation directly in hydraulic and pneumatic cylinders.

IMCA and KAB electronics (explanation see page 5) have a built-in cable breakage monitoring and are entirely galvanically isolated. The signal output is optimized for interference compatibility with very low residual noise - the guarantee for ultimate resolution and measuring accuracy.

## TECHNICAL DATA

Sensor							
Measurement range FS [mm]	0...2	0...5	0...10	0...25	0...50	0...100	0...200
Linearity [% of FS]	0.30 % (0.20 % optional, 0.10 % for selected models)						
Types	spring loaded (up to range 0...50 mm), free core, push rod guided/ unguided						
Protection class cable/ connector side	IP67, optional IP68						
Protection class flange side	IP68/ 150bar						
Vibration stability DIN IEC68T2-6	10 G						
Shock stability DIN IEC68T2-27	200 G/ 2 ms						
Supply voltage/ frequency	3 V <sub>eff</sub> / 3 kHz						
Supply frequency	2...10 kHz						
Temperature range	-40...+120 °C (H option: 150 °C , H-200 option: 200 °C)						
Mounting	thread M18x1,5						
Housing	stainless steel 1.4301, chrome plated steel						
Connection	cable output or M12-connector with coupling nut						
cable TPE (standard)	ø 4.5 mm, 0.14 mm <sup>2</sup> , non-halogen, suitable for drag chains						
PTFE (option H)	ø 4.8 mm, 0.24 mm <sup>2</sup> , max. temperature 200°C, UL-Style 2895						
Max. cable length	100 m between sensor and electronics						

Spring loaded version (up to range 50 mm)							
Spring force (middle of range) [N]	0.9	0.9	0.9	0.95	0.95	-	-
Max. cycles of tip at 1 mm amplitude [Hz]	55	50	50	35	20	-	-
Spring stiffness [N/ mm]	0.29	0.2	0.12	0.06	0.04	-	-
Life cycle	> 10 Mio. cycles						

Free core/ push rod/ push rod guided							
Max. acceleration of core/ push rod	100 G						
Life cycle	infinite						
Weight approx. [g]	85	91	96	108	140	190	290

Electronics	IMCA external electronics (built-in)	KAB cable electronics
Output signal	0...20 mA, 4...20 mA (load < 300 Ohm) 0...5 V, ± 5 V (load > 5 kOhm) 0...10 V, ± 10 V (load > 10 kOhm)	4...20 mA (load < 300 Ohm) 0...5 V, ± 5 V (load > 5 kOhm) 0...10 V, ± 10 V (load > 10 kOhm)
Temperature coefficient	-0,0055, ±0,002 %/K	
Resolution*	0,04 % FS	
Corner frequency	300 Hz/-3 dB (6-pole Bessel)	
Isolation stability	> 1000 VDC	
Power supply	9...36 VDC	
Current consumption	75 mA at 24 VDC 150 mA at 12 VDC	65 mA at 24 VDC 140 mA at 12 VDC
Sensor supply	3 V <sub>eff</sub> , 3 kHz (adjustable, 1-18 kHz)	
Working temperature	-40...+85 °C	
Storage temperature	-40...+85 °C	
Housing	polyamide PA6.6, meets UL94-VO	aluminium
Mounting	on DIN EN-rail	-

\* 98.5% confidence interval (confidence limit)

# TECHNICAL DIMENSIONS

range FS [mm]	body length B cable/ connector radi- al[mm]	body length C connector M12 [mm]	max. length A sprung load mechanics [mm]	core length D [mm]	push rod length E [mm]
0...2	57	60	39	22	62
0...5	63	66	42	25	68
0...10	73	76	47	30	78
0...25	103	106	62	45	108
0...50	153	156	87	70	158
0...100	253	256	-	120	258
0...200	453	456	-	220	458

Other measurement ranges are available on request.

## type: free core, push rod unguided

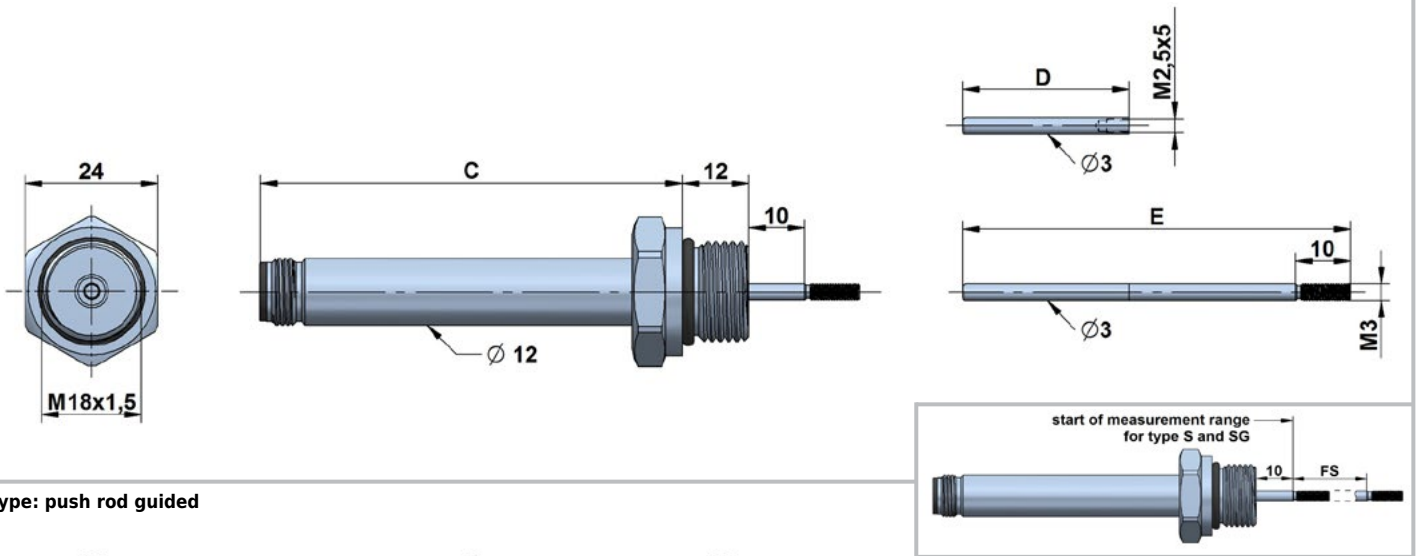

## type: push rod guided

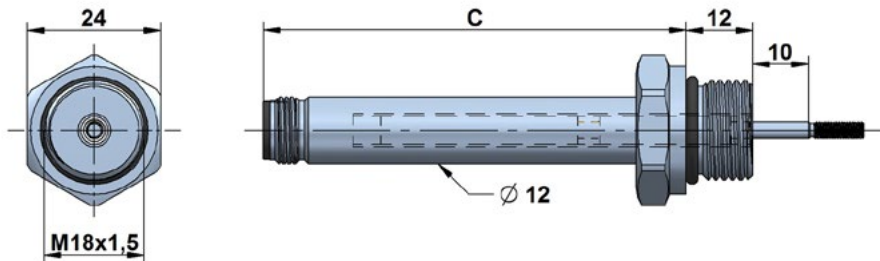

## type: spring loaded (up to range 0...50 mm)

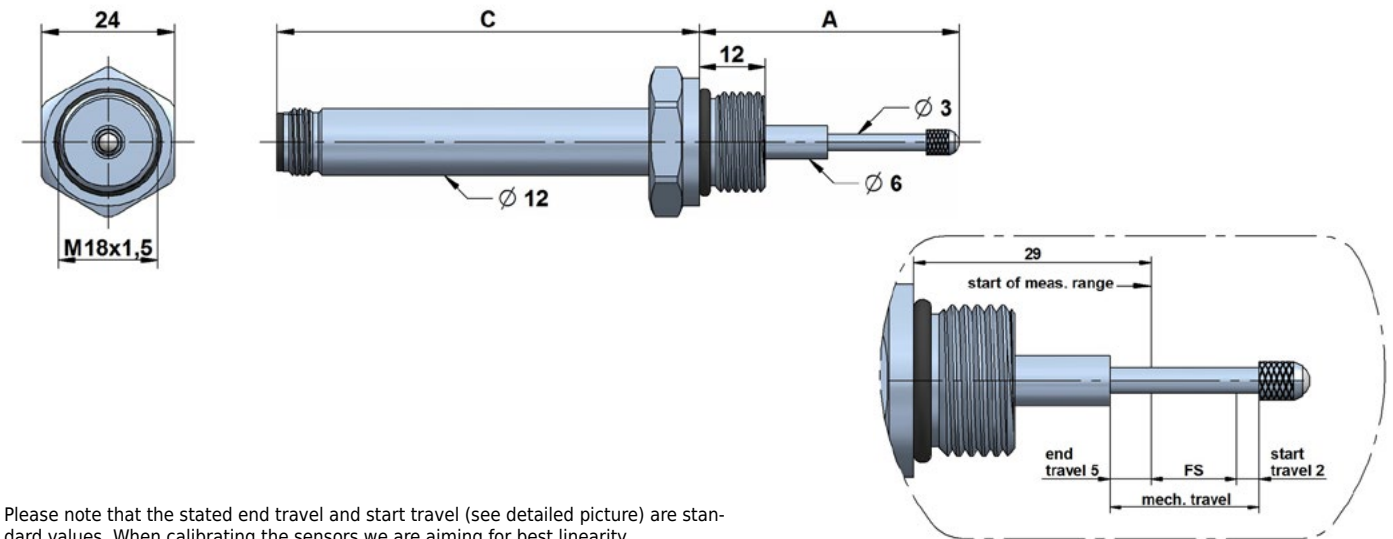

Please note that the stated end travel and start travel (see detailed picture) are standard values. When calibrating the sensors we are aiming for best linearity.

## SENSOR TYPES

### Cable output axial

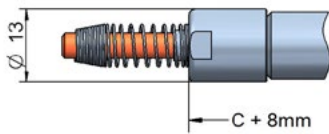

Sensors with cable output have a cable fitting and a spring for bend protection of the cable.

For installation, the bending radius should not be less than 3 times the cable diameter. The standard cable length is 2 m.

Instruments with option H for temperatures up to 150 °C/ 200 °C feature a PTFE cable.

### Cable/ connector output radial

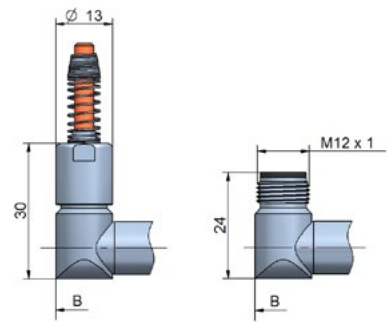

### Connector output (cable with straight or angular connector)

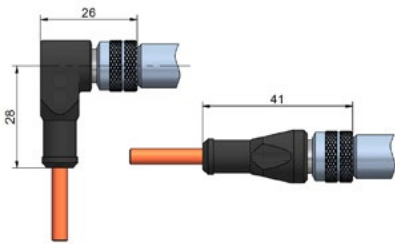

For sensors with connector output the cable has to be ordered separately. You can choose from a cable with a straight connector or with an angular connector.

The connector is protected from accidental removal by a threaded fitting (M12). The cable lengths are 2/ 5/ 10 m.

The connector pair has protection class IP67.

The total length of the sensor with connector is:  
body length of the connector M12 (see table) + 20 mm (angular connector)  
body length of the connector M12 (see table) + 37 mm (straight connector)

### Option VH

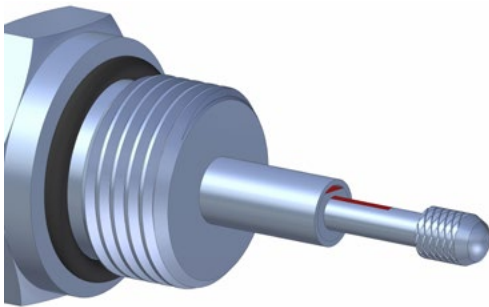

The option VH should be chosen, if the sensor is used in liquids (oil, water, ...) or if fast pressure variations may occur. By milling plane surfaces on parts of the mechanics (see picture red marked) the pressure balance or venting of the inside area will be improved.

For „spring loaded version“: Two plane surfaces combined with a higher spring force of approximately 2,5 N improve significantly the mechanical performance.

For version „guided push rod“: The push rod features a plane surface.

## INSTALLATION DRAWING

flange with thread M18

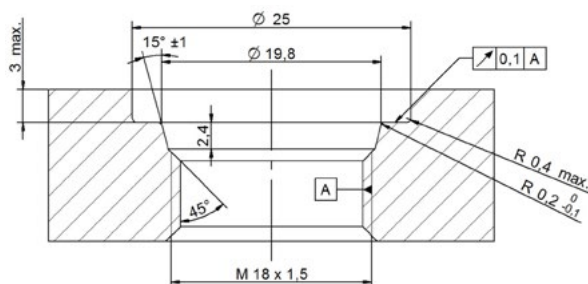

\* note: Rz = 1,6 for non pulsating pressure  
Rz = 0,8 for pulsating pressure

## AC-OUTPUT

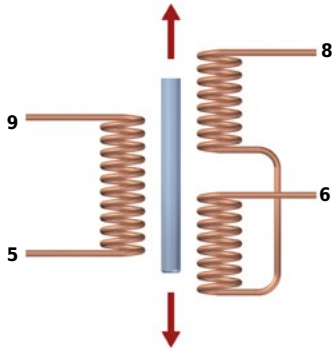

**assignment for TPE-cable:**  
 white (5): primary 2  
 black (6): secondary 2  
 brown (9): primary 1  
 blue (8): secondary 1

**assignment for PTFE-cable:**  
 white (5): primary 2  
 green (6): secondary 2  
 yellow (9): primary 1  
 brown (8): secondary 1

**assignment M12-connector:**

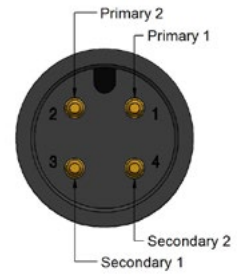

## CABLE ELECTRONICS KAB

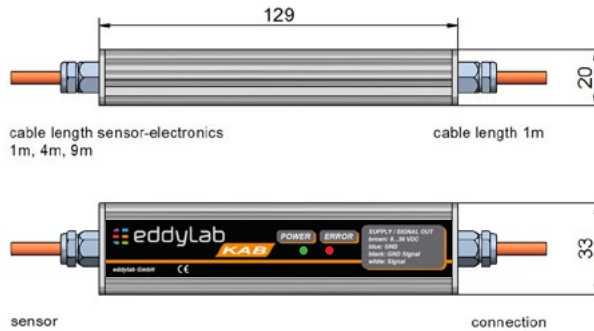

**assignment for TPE-cable:**  
 brown: supply V+  
 blue: GND  
 black: output GND  
 white: output signal

**assignment for PTFE-cable:**  
 yellow: supply V+  
 brown: GND  
 green: output GND  
 white: output signal

If not specified otherwise the cable electronics is placed at 1 m from the end of the cable. On request in your order, however, the cable electronics can be placed at any position.

## EXTERNAL ELECTRONICS IMCA



external electronics IMCA  
(for DIN-rail mounting)

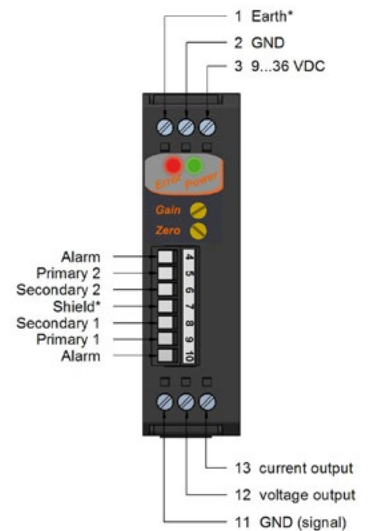
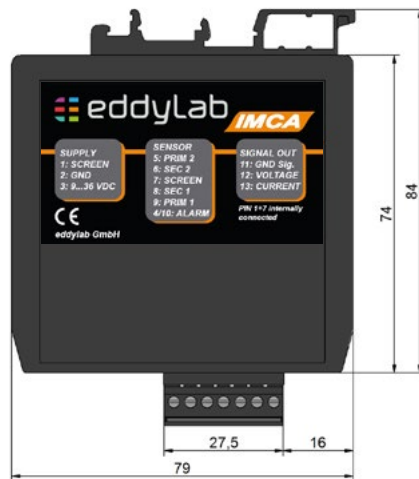

### Connection

The external electronics IMCA is designed to be installed in switch cabinets (Din-rail mounting). The connection to the sensor is conducted as connector with push-in spring connection.

\* Terminals 1 and 7 are internally connected.

At harsh EMC environments, it is possible to install the electronics at a max. distance of 100 m in a switch cabinet. A twin twisted pair cable (4-cores, minimum cross section 0,5 mm<sup>2</sup>), single or double shielded, is to be used for the further wiring to connect the external electronics to the system. It is recommended to ground the shield in the switch cabinet near the electronics (do not ground at the machine/ sensor). The sensor housing is grounded at the machine frame. To prevent interference, the cable length should not exceed 100 m.

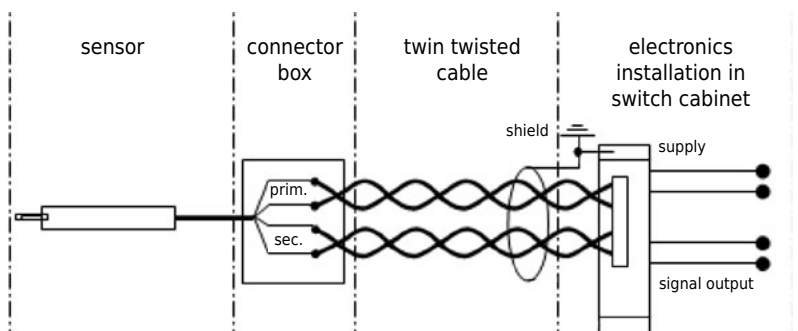



## ADJUSTMENT OF ZERO POINT AND GAIN

Please note that the zero point and gain may shift for long cable length between sensor and electronics. Thus install the sensor with the according cable length to the electronics and then adjust zero point and gain.

1. Push rod entirely in - adjust offset.  
Move the sensor to the zero point of the measuring range and set the offset potentiometer on 4 mA/0 V for the output signal.
2. Push rod entirely out - adjust gain  
Move the sensor to the end of the measuring range (push rod moved out) and set the gain potentiometer on 20 mA /10 V/5 V for the output signal.

The output signal is referring to the electric measuring range. If the sensor is operated outside the measuring range or the measuring range is exceeded, the signal is also outside the defined range (i.e. > 10 V/ 20 mA or < 0 V/ 4 mA, in the graph: > 100 % or < 0 %). Please keep this in mind for control systems with cable break detection lower than 4 mA or for a maximum input voltage > 10 V of measuring instruments. If necessary install the sensor **before** connecting to the PLC.

Running direction of signal: If the push rod is moving into the sensor (e.g. sprung load pushed in), the signal is reducing. If the push rod is moving out, the output signal is increasing. The running direction of the signal can also be inverted.

Signal inversion:

If an inverted output signal is required (20...4 mA /10...0 V/5...0 V), swap clamps 6 and 8 (secondary coil) on the external electronics.

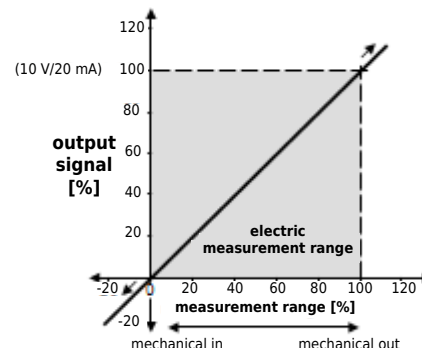

## CABLE BREAK DETECTION

The electronics by WayCon feature a built-in cable break detection. This is achieved by an impedance measurement of the LVDT's secondary coil. If the sensor cable is cut, the impedance on the secondary connections of the electronics change regardless of the push rod position, triggering the cable break detection. This feature is based on a broken secondary connection. A partial cable break of the primary connections (cables between primary coil and electronics) will not activate this function. The electronics vary in their functional range. The external electronics IMCA offers the widest range. The cable electronics KAB only visualises a cable break by a red LED.

IMCA: For the use of the cable break functions an alarm system (signal lamp, acoustic alarm device) or an alarm input of the PLC must be connected to the 7-pole terminal. The circuit board features a analog switch which is a normally open.

Normal operation IMCA:

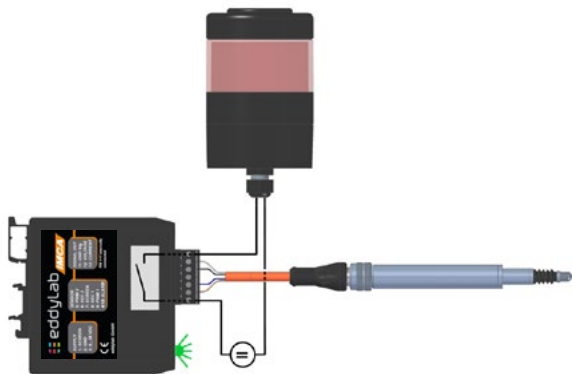

- The green „POWER-LED“ on the front side is on.
- The signal output is active.
- The alarm output is disabled.

Cable break IMCA:

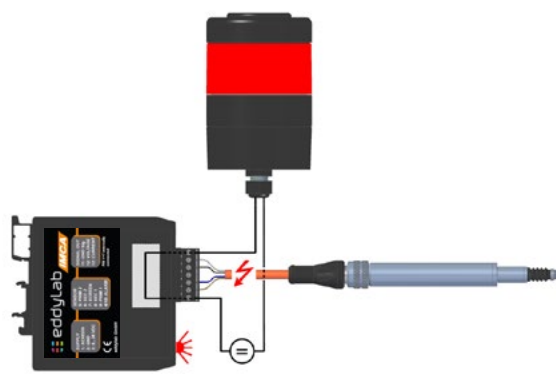

- In case of a cable break the analog switch closes and the alarm system is activated or an electrical signal is conducted. Please note the maximum electrical values; 30 mA or 14 V.
- A front side „ERROR-LED“ flashes in case of an error.
- The signal output is deactivated. There is no current or voltage signal.

Normal operation KAB:



- The green „POWER-LED“ is on.

Cable break KAB:



- The red „ERROR-LED“ is on.

## ORDER CODE

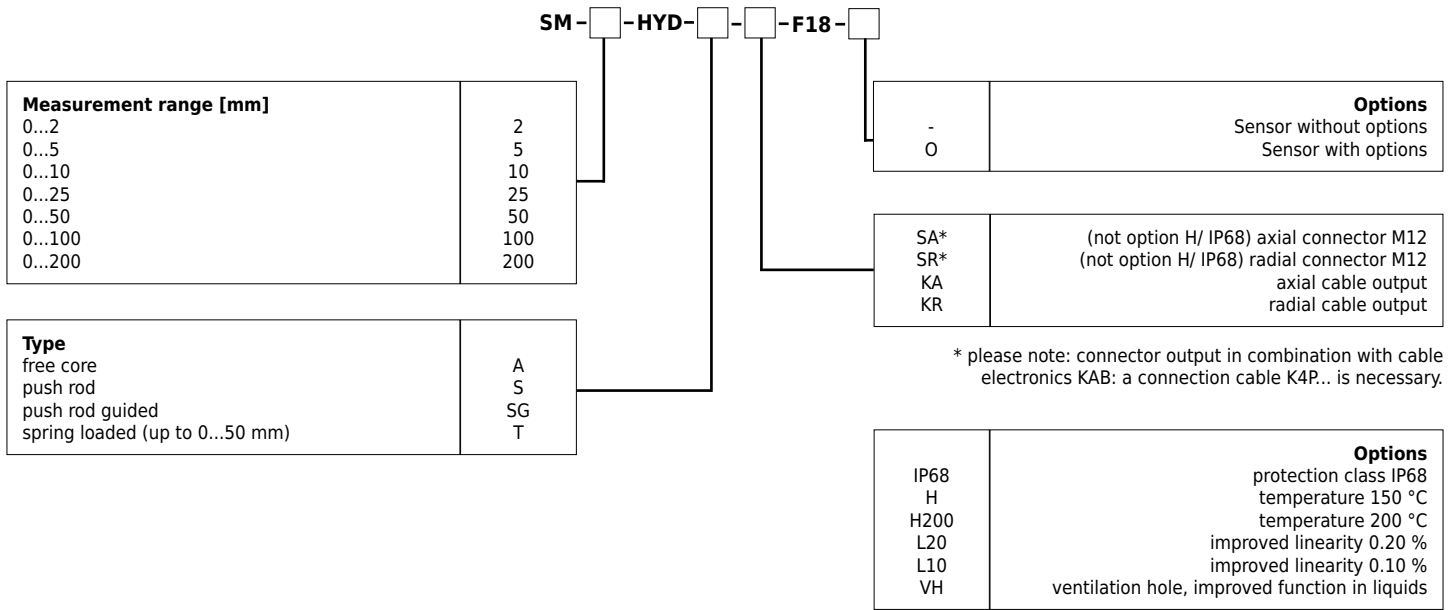

## ORDER CODE ELECTRONICS

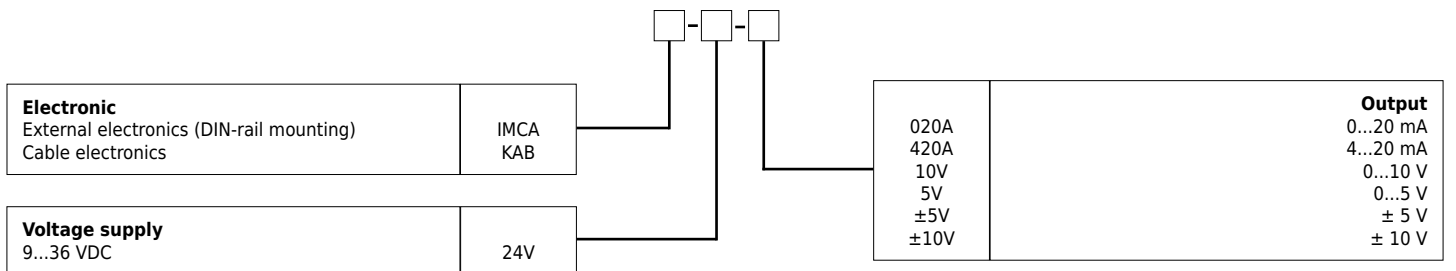

## ACCESSORIES

### Connection cable with M12 connector

K4P2M-S-M12	2 m, straight connector
K4P5M-S-M12	5 m, straight connector
K4P10M-S-M12	10 m, straight connector
K4P2M-SW-M12	2 m, angular connector
K4P5M-SW-M12	5 m, angular connector
K4P10M-SW-M12	10 m, angular connector

### Additional cable (2 m length is standard)

Kabel-TPE	order code for 1 meter of additional TPE cable
Kabel-PTFE-UL	order code for 1 meter of additional PTFE cable

### Mating connector (for self assembly)

D4-G-M12-S	straight, M12, shielded
D4-W-M12-S	angular, M12, shielded



Subject to change without prior notice.