

DRAW WIRE SENSOR



Series SX120

Key-Features:

- Measurement ranges from 3125 to 5000 mm
- Analog Output: Potentiometer, 0...10 V, 4...20 mA
- teachable outputs: 0...5 V, 0...10 V, with an additional Open-Collector switching output
- Digital Output Incremental: RS422 (TTL), push-pull
- Digital Output Absolute: CANopen, SSI, Profibus, EtherCAT, Profinet
- Linearity up to $\pm 0.02\%$ of full scale
- Protection class up to IP67
- Temperature range -20...+85 °C (optional -40 °C or +120 °C)
- High dynamics
- High interference immunity factor
- Customised versions available

Content:

Introduction2
Analog Output3
Digital Output Incremental6
Digital Output Absolute8
CANopen, SSI9
Profibus, EtherCAT	..10
Profinet	..11
Options	..12
Accessories	..13
Installation	..15
Order Code	..16

INTRODUCTION

WayCon Positionsmesstechnik GmbH is a manufacturer of high quality draw wire position sensors for industrial use. Due to its small overall size, its short assembly time and its possible customisation, the SX sensor technology is a cost-effective and flexible solution for a wide range of industrial applications. The dynamics of the draw wire transducer allows a high motion speed and acceleration of the measuring target. Its rugged design and high quality makes applications in harsh industrial environments possible. Special instruments are available with mounting service of encoder on site, as well as customised versions of housing.

Sensor principle:

The key component of a draw wire sensor is a highly flexible steel wire rope, that is wound single-layered on an ultra light capstan. This capstan is connected to the sensor housing by a pre-stressed spring. The end of the steel wire rope, that is equipped with a rope clip gets connected to the target object. As soon as the distance between sensor and target object changes, the steel wire rope gets pulled out of the sensor and is rolled off the capstan (or vice versa). The shaft of the capstan is connected to a potentiometer (for analog output signals), or to an encoder (for digital output signals). If there is a rotation of the capstan due to a change in the distance to the target object, the sensor element will turn proportionally. This way the potentiometer, or the encoder converts a linear movement into a proportional electrical signal. If a standard analog output signal, like 0...10 V or 4...20 mA is needed, the sensor is equipped with an additional electronics.

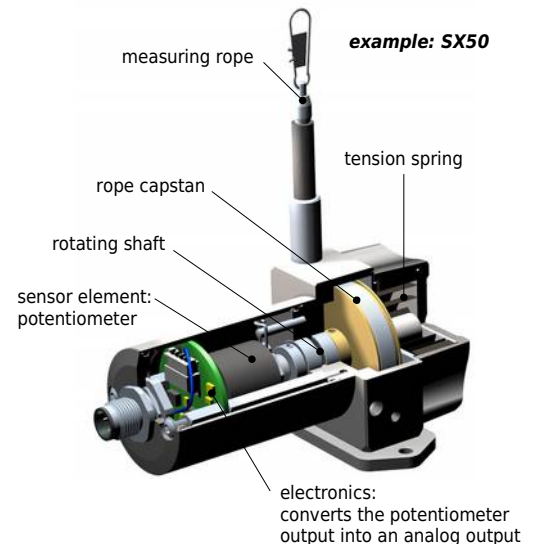

SPECIAL FEATURES

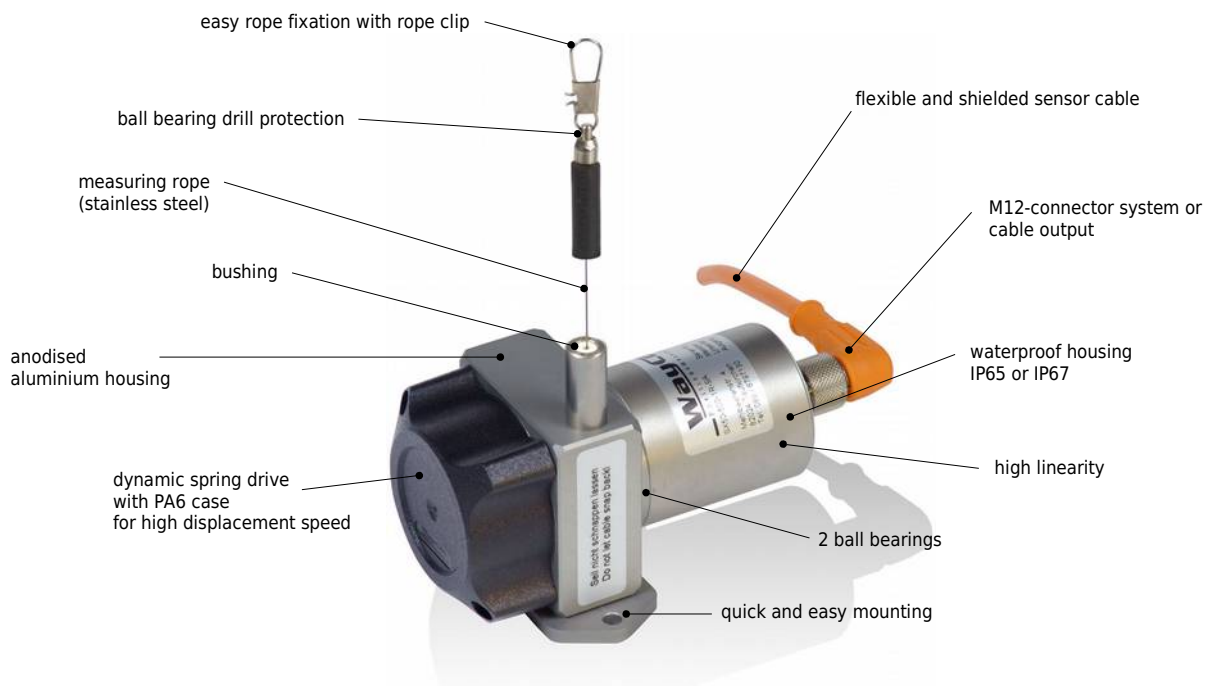

WARNING NOTICES

- Don't let the rope snap back. If the rope is retracted freely, this may lead to injuries (whiplash effect) and the device may be damaged. Caution when unhooking and retracting the rope into the sensor.
- Never exceed the specified measurement range when extracting the rope!
- Do not try to open the device. The stored energy of the spring drive may lead to injuries when being mishandled.
- Do not touch the rope when operating the sensor.
- Avoid guiding the rope over edges or corners. Use a deflection pulley instead.
- Do not operate the sensor if the rope is buckled or damaged. A ripping of the rope may lead to injuries or a damaging of the sensor.



TECHNICAL DATA ANALOG OUTPUT

Measurement range *	[mm]	3125	4000	5000
Linearity	[%]	0.10	0.10	0.10
Improved linearity (optional)	[%]	0.05	-	-
Resolution		see types of output table below		
Sensor element		Hybrid Potentiometer		
Connection		connector output M12 axial or cable output axial (TPE cable, standard length 2 m)		
Protection class		IP65, optional IP67		
Humidity		maximum 90 % relative, no condensation		
Temperature	[°C]	standard: -20...+85 / optional: -40...+85 / optional: -20...+120 °C (only with Potentiometer (1R) and cable output (KA))		
Mechanical data		extraction force, maximum velocity and maximum acceleration see table page 13		
Weight	[g]	300 to 500, depending on the measurement range		
Housing		aluminium, anodised, spring case PA6		
Accessories		cables, connectors, digital displays, deflection pulley, rope extensions, magnetic clamp (see pages 11 and 12)		

* other ranges on request

TYPES OF ANALOG OUTPUT

Output: Potentiometer (voltage divider)

Output	1 kΩ
Supply	max. 30 V
Recommended cursor current	< 1 μA
Resolution	theoretically unlimited, limited by the noise
Noise	dependent on the quality of the power supply
Working temperature	-20...+85 °C, optional: -40...+85 °C / -20...+120 °C
Temperature coefficient	± 0.0025 %/K

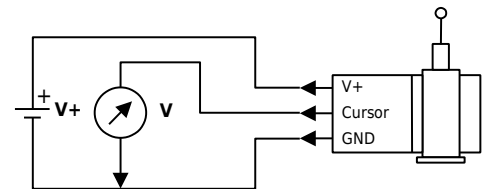

Output: Voltage 0...10 V

Output	0...10 V, galvanically isolated, 4 conductors
Supply	12...30 VDC
Current consumption	max. 22.5 mA (unloaded)
Output current	max. 10 mA, min. load 10 kΩ
Dynamics	< 3 ms from 0...100 % and 100...0 %
Resolution	limited by the noise
Noise	3 mV _{pp} typical, max. 37 mV _{pp}
Inverse-polarity protection	yes, infinite
Short-circuit proof	yes, permanent
Working temperature	-20...+85 °C, optional: -40...+85 °C
Temperature coefficient	0.0037 %/K
Electromagnetic compatibility (EMC)	according to EN 61326-1:2006

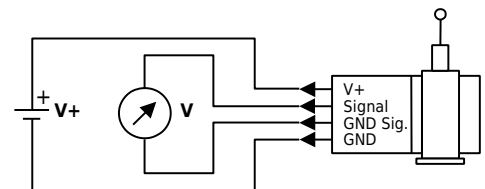

Note: GND Sig. and GND may be connected in a 3-wire system.

Output: Current 4...20 mA

Output	4...20 mA, 2 conductors
Supply	12...30 VDC
Output current	max. 50 mA in case of error
Dynamics	< 1 ms from 0...100 % and 100...0 %
Resolution	limited by the noise
Noise	0.03 mA _{pp} = 6 mV _{pp} at 200 Ω
Inverse-polarity protection	yes, infinite
Working temperature	-20...+85 °C, optional: -40...+85 °C
Temperature coefficient	0.0079 %/K
Electromagnetic compatibility (EMC)	according to EN 61326-1:2006

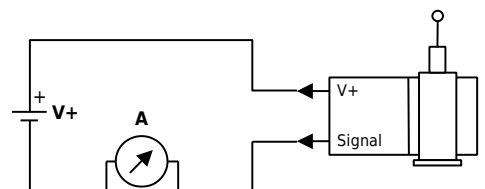

TYPES OF ANALOG OUTPUT

Output: Voltage 0...5 V, 0...10 V teachable up to approx. 50% of full scale

Output	0...5 V, 0...10 V, 3 wire system
Supply	8...35 VDC
Power consumption	max. 150 mW
Output current	max. 10 mA, min. load 1 kOhm
Dynamics	1 ms
Resolution	1 mV
Noise	3 mV _{ss} typical, max. 37 mV _{ss}
Inverse-polarity protection	yes, infinite
Short-circuit proof	yes, permanent
Working temperature	-40...+85 °C
Temperature coefficient	0.0016 %/K
Electromagnetic compatibility (EMC)	according to EN 61326-1:2006

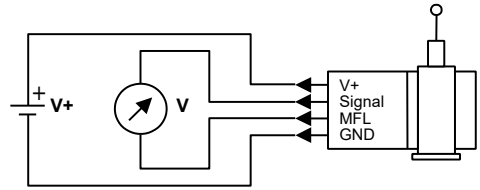

MFL: Multi-functional line

TEACHABLE OUTPUT 5VT, 10VT, SQUEEZER

The signals provided by the potentiometer are digitized by the VT-Electronics. This digital information is first processed by the electronics, then transformed back and given out as an analogue output signal 0 to 10 V or 0 to 5 V.

The digitization offers two possibilities of adjustment, by which the sensor can be configured individually using the squeezer:

- 1) Teaching of the measurement range. After a successful teaching process the squeezer can be pulled off the sensor and be replaced by a standard cable or connector.
- 2) Setting an individual switching point. The squeezer allows the setting of an individual switching point open collector. The switching signal is emitted through the Multi-functional line MFL.

You will find a detailed description of the functions in a separate manual.

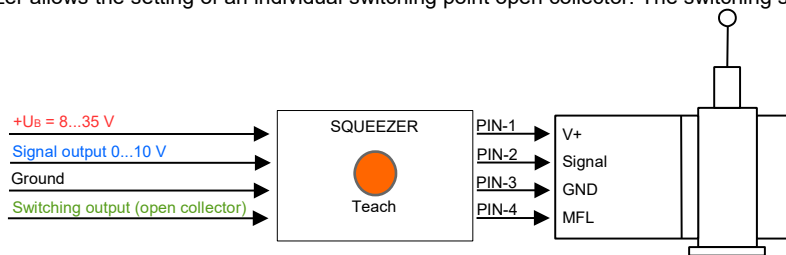

TECHNICAL DRAWING SQUEEZER

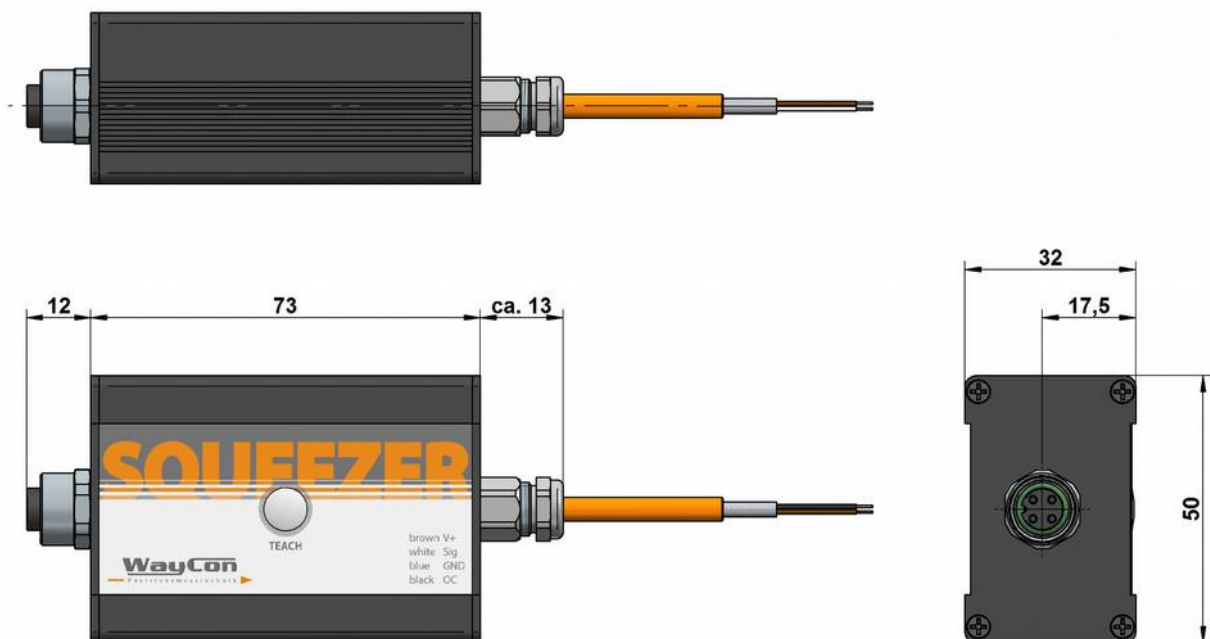

TECHNICAL DRAWING ANALOG OUTPUT

Analog Output

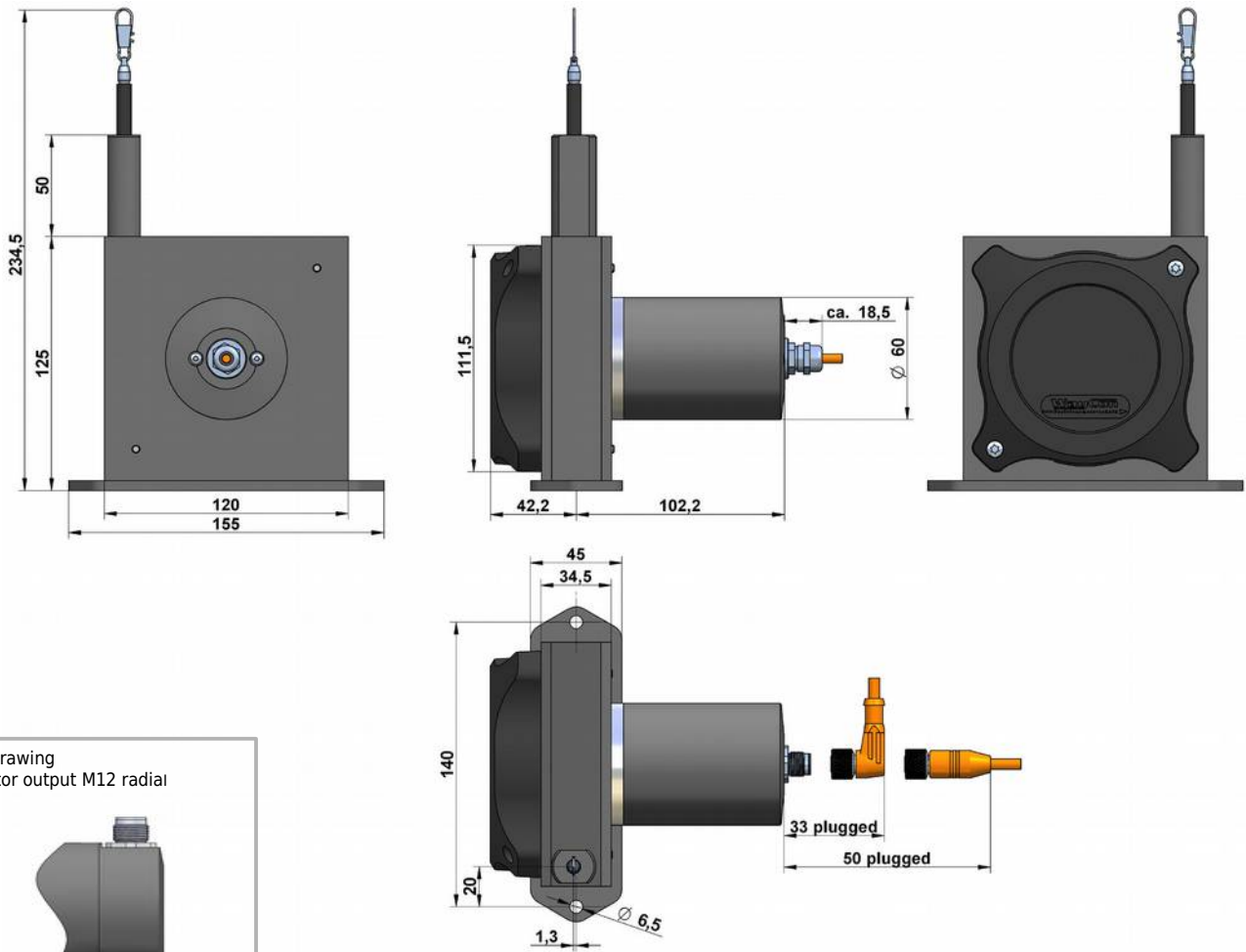

Detail drawing
connector output M12 radial



ELECTRICAL CONNECTION ANALOG OUTPUT

Cable output

Cable type	TPE, flexible		
Cable direction	axial		
Length	standard: 2 m, (others on request)		
Diameter	4.5 mm		
Wire	0.25 mm ²		
Temperature	fixed installation -30...+85 °C		
	flexible installation -20...+85 °C		
Cable colour	0...10 V	4...20 mA	1 kOhm
brown	V +	V +	V +
white	Signal	n. c.	Cursor
blue	GND	Signal	GND
black	GND Signal	n. c.	n. c.

Connector output, M12, 4 poles

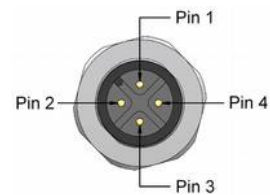

Pin	0...10 V	4...20 mA	1 kOhm
1	V +	V +	V +
2	Signal	n. c.	Cursor
3	GND	Signal	GND
4	GND Signal	n. c.	n. c.

TECHNICAL DATA DIGITAL OUTPUT INCREMENTAL

Measurement range *	[mm]	3125 / 4000 / 5000
Linearity	[%]	0.05, independent of the measurement range
Improved linearity (optional)	[%]	0.02, independent of the measurement range, only in combination with resolution 6.3 pulses/mm, or higher
Selectable resolution	[Pulses/mm]	0.3 / 3.1 / 6.3 / 15,7 (this resolution can be raised by the factor 4 using quadruple edge detection)
Z-Pulse distance	[mm]	317.68
Sensor element		Incremental-Encoder (with optical code disk)
Output signal		A/B-Pulses (90° phase-delayed), Z-Pulse (plus inverted pulses A_{not} , B_{not} , Z_{not})
Connection		M12 or M23 connector output or cable output with open ends (standard length 2 m)
Protection class		IP65, optional IP67
Humidity		maximum 90 % relative, no condensation
Temperature range	[°C]	-20...+85
Mechanical data		extraction force, maximum velocity and maximum acceleration see table page 13
Life expectancy		approx. 2 million full strokes (dependent on the displacement speed)
Weight	[g]	1300 - 1600, depending on the measurement range
Housing		aluminium, anodised, spring case PA6
Accessories		digital displays, deflection pulley, rope extensions, magnetic clamp (see pages 12 and 13)

* other ranges on request

Electrical Data		Linedriver L	Push-Pull G
		RS422 (TTL-compatible)	
Power supply +V	[VDC]	5, ±5 %	8...30
Current consumption (no load)	[mA]	typical 40, max. 90	typical 40, max. 100
Load/ Channel	[mA]	max. ±20	max. ±40
Pulse frequency	[kHz]	max. 300	max. 200
Signal level high	[V]	min. 2.5	min. +V - 3
Signal level low	[V]	max. 0.5	max. 0.5

Recommended circuit

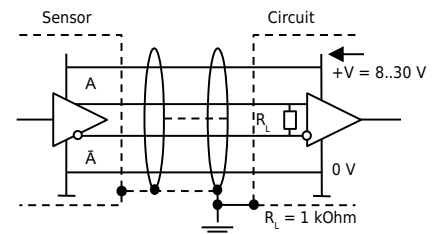
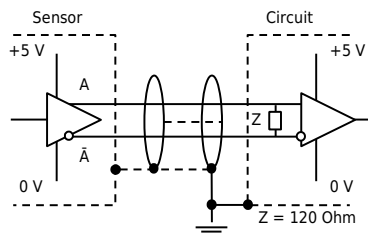

OUTPUT SIGNAL DIGITAL OUTPUT INCREMENTAL

Output signal

Pulses A and B are 90° phase-delayed (detection of direction). The Z-Pulse is emitted once per turn. The Z-Pulse distance is 317.68 mm (= circumference of the rope drum) and can be used as a reference mark.

The diagram shows the signal without inverted signals; time line for return of rope.

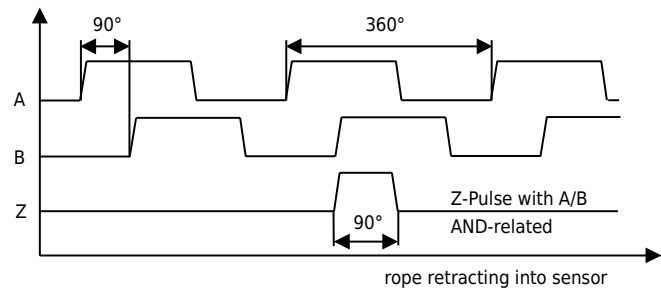

TECHNICAL DRAWING DIGITAL OUTPUT INCREMENTAL

Digital Output Incremental

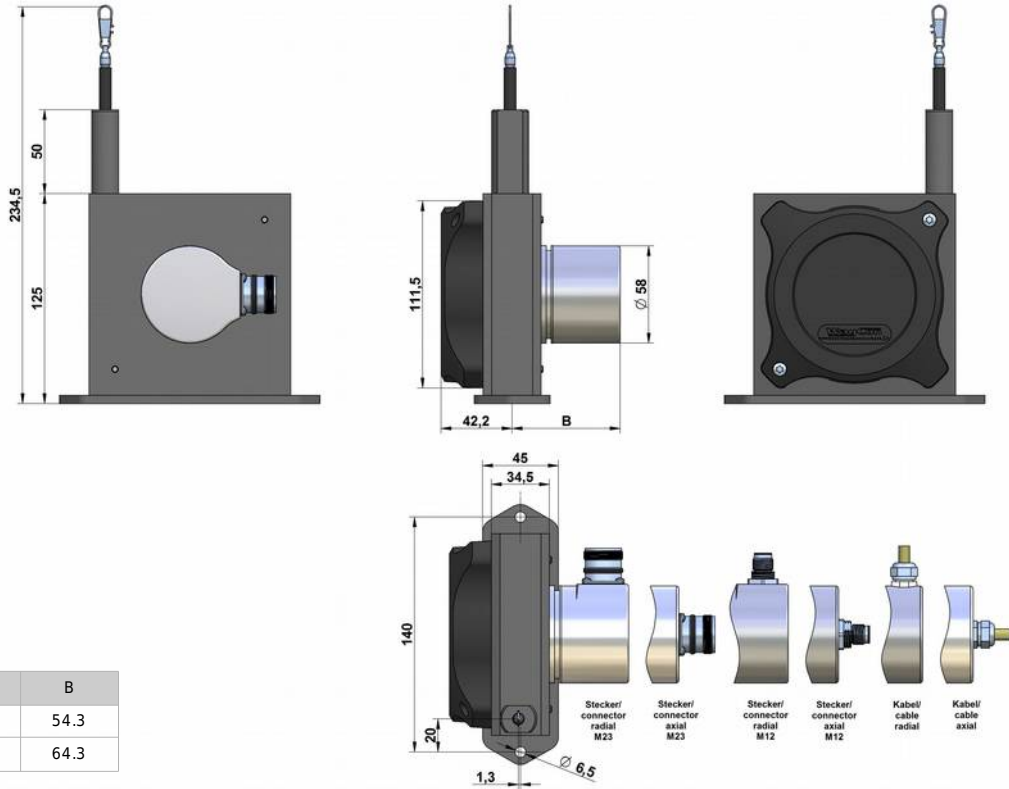

Option	B
cable/ connector axial, cable radial	54.3
connector radial	64.3

CONNECTION DIGITAL OUTPUT INCREMENTAL

Signal	0 V	+V	0 V _{sens} *	+V _{sens} *	A	A _{Not}	B	B _{Not}	Z	Z _{Not}	screen
Connector M23, 12-pole	10	12	11	2	5	6	8	1	3	4	housing
Connector M12, 8-pole	1	2	-	-	3	4	5	6	7	8	housing
Cable output	white	brown	black	violet	green	yellow	grey	pink	blue	red	housing

* For Linedriver L only. For long cable lengths it may occur that the operating voltage at the sensor does not suffice due to the output resistance. With the sensor lines 0 V_{sens} and +V_{sens} the operating voltage can be checked and, if necessary, be readjusted at the input connection.

+V:	Encoder power supply +VDC	A, A _{Not} :	Incremental output channel A
0 V:	Encoder power supply ground GND (0 V)	B, B _{Not} :	Incremental output channel B
0 V _{sens} / +V _{sens} :	Using the sensor outputs of the encoder, the voltage present can be measured and if necessary increased accordingly	Z, Z _{Not} :	Reference signal

Connector output, M23, 12 poles

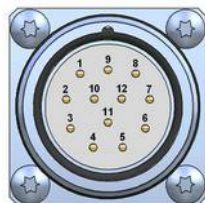

Connector output, M12, 8 poles

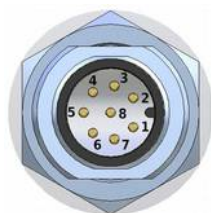

Cable output

Cable type	PVC, flexible
Cable direction	radial or axial
Length	2.0 m
Diameter	ø 4.5 mm
Wires	8 (push-pull) and 10 (linedriver) x 0.14 mm ²
Temperature	fixed installation -30...+85 °C flexible installation -20...+85 °C
Assignment	see table above

TECHNICAL DATA DIGITAL OUTPUT ABSOLUTE

		CANopen	SSI	Profibus-DP	EtherCAT	Profinet
Measurement range	[mm]	3125 / 4000 / 5000				
Linearity	[%]	0.05, independent of the measurement range				
Resolution scalable (with Software)		yes	no	yes	yes	yes
Standard resolution	[Pulses/mm]	25,79	12,89	25,79	25,79	25,79
	[Bit]	13	12	13	13	13
Maximum resolution	[Pulses/mm]	206.3	-	206.3	206.3	206.3
	[Bit]	16	-	16	16	16
Sensor element		Multiturn-Absolute-Encoder (with optical code disk)				
Electrical connection		see order code page 16				
Power supply	[VDC]	10...30 (reverse polarity protection of the power supply)				
Current consumption (no load, 24 V)	[mA]	max. 100	max. 50	max. 120	max. 120	max. 200
Protection class		IP65, optional IP67				
Humidity		max. 90 % relative, no condensation				
Temperature	[°C]	-20...+80				
Mechanical data		extraction force, maximum velocity and maximum acceleration see table page 14				
Life expectancy		approx. 2 million full strokes (dependent on the displacement speed)				
Weight	[g]	approx. 1100				
Housing		aluminium, anodised, spring case PA6				
Special cables needed		yes	yes	yes	yes	yes
Accessories		cable, connector, digital display, deflection pulley, rope extensions, magnetic clamp (see pages 12 and 13)				

Other encoder types are available on request

TECHNICAL DRAWING DIGITAL OUTPUT ABSOLUTE

Note: for dimensions of the sensor housing please see page 4.

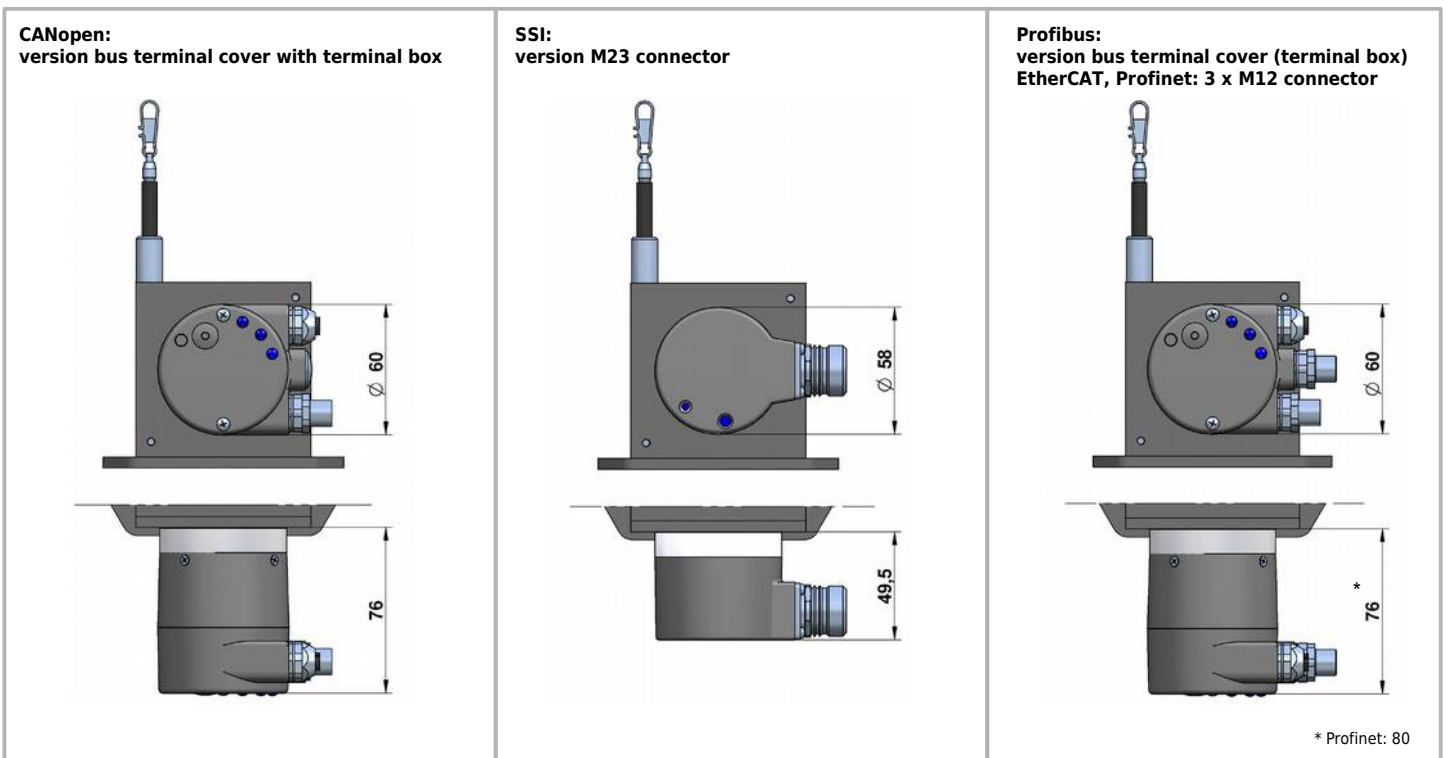

DESCRIPTION CANopen

Parameters of the CANopen Interface

Code	Binary
Interface	CAN High-Speed acc. to ISO 11898, Basic- and Full-CAN, CAN Specification 2.0 B
Protocol	CANopen profile DS406 V3.2 with manufacturer-specific add-ons
Baud rate	10 ... 1000 kbit/s (can be set via DIP switches/ Software configurable)
Node address	1...127 (can be set via rotary switches/ Software configurable)
Termination switchable	can be set via DIP switches/ Software configurable
SET Button (Option)	Zero or defined value option
LED	LED is ON with the following fault conditions: Sensor error (internal code or LED error) too low voltage, over-temperature

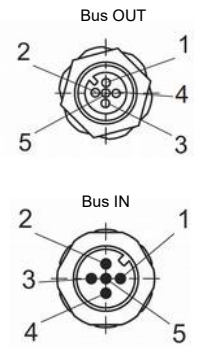

Electrical connection CANopen with 2 x M12 connectors, radial

Signal	Bus OUT					Bus IN				
	0 V	+ V	CAN_L	CAN_H	CAN_GND	0 V	+ V	CAN_L	CAN_H	CAN_GND
PIN	3	2	5	4	1	3	2	5	4	1

Electrical connection CANopen with cable gland radial (removable bus terminal cover)

Signal	Bus out					Bus in				
	CAN_GND	CAN_L	CAN_H	0 V	+V	0 V	+V	CAN_L	CAN_H	CAN_GND
Abbreviation	CG	CL	CH	0 V	+V	0 V	+V	CL	CH	CG

DESCRIPTION SSI

Parameters of the SSI interface

Output driver	RS485 Transceiver-type
Permissible load/channel	max. ±20 mA
Signal level	HIGH: typ 3.8 V LOW: with $I_{Load} = 20 \text{ mA}$ typ 1.3 V
Resolution	12 bit
Code	Gray
SSI clock rate	ST-resolution: 50 kHz...2 MHz
Monoflop time	≤ 15 μs
Data refresh rate	≤ 1 μs
Status and Parity bit	on request

SET Input (optional)

Input	active HIGH
Input type	comparator
Signal level	HIGH: min 60% of +V, max. +V LOW: max. 25% of +V
(+V = power supply)	
Input current	<0.5 mA
Min. pulse duration (SET)	10 ms
Input delay	1 ms
New position data readable after	1 ms
Internal processing time	200 ms

Electrical connection SSI with cable output

Signal	Cable (Isolate unused wires individually before initial start-up)												
	0V	+V	C+	C-	D+	D-	SET	DIR	Status	n.c.	n.c.	n.c.	H
Colour	white	brown	green	yellow	gray	pink	blue	red	black	-	-	-	shield

Electrical connection SSI with connector output M23, 12 pole

Signal	M23 connector												
	0V	+V	C+	C-	D+	D-	SET	DIR	Status	n.c.	n.c.	n.c.	H
PIN	1	2	3	4	5	6	7	8	9	10	11	12	shield

- + V: Encoder power supply +VDC
- 0 V: Encoder power supply GND (0 V)
- C+, C-: Clock signal
- D+, D-: Data signal
- SET: SET Input
- DIR: Direction input: If this input is active, output values are counted backwards (decrease) when the shaft is turning clockwise.
- H: Plug connector housing (Shield)

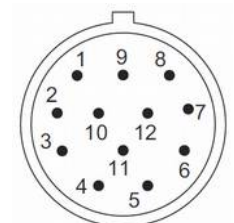

DESCRIPTION PROFIBUS DP

Parameters of the Profibus DP interface



Code	Binary
Interface	Profibus DP 2.0 Standard (DIN 19245 Part 3), RS485 Driver galvanically isolated
Protocol	Profibus Encoder Profile V1.1 Class1 and Class2 with manufacturer-specific add-ons
Baud rate	maximum 12 Mbit/s
Device address	1...127 (set by rotary switches)
Termination switchable	set by DIP switches
SET Button (Option)	Zero or defined value option
LED	LED is ON with the following fault conditions: Sensor error, Profibus error

Electrical connection Profibus with cable gland radial (removable bus terminal cover)

	Bus IN				Bus OUT			
Signal	B	A	0 V	+V	0 V	+V	B	A
Terminal	1	2	3	4	5	6	7	8

The shield of the connection cable must be connected over a large area via the cable gland.

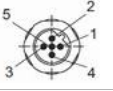
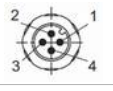
Electrical connection Profibus with connector output 3 x M12

Bus IN	Signal	-	PB_A	-	PB_B	shield	
	PIN	1	2	3	4	5	
Power supply	Signal	+V	-	0 V	-		
	PIN	1	2	3	4		
Bus OUT	Signal	BUS_VDC*	PB_A	BUS_GND*	PB_B	shield	
	PIN	1	2	3	4	5	



* For supplying an external Profibus termination resistor

DESCRIPTION EtherCAT

Parameters of the Ether CAT Interface

Code	Binary
Protocol	EtherNet / EtherCAT
Modes	Freerun, Distributed Clock
Diagnostic LED red	LED is ON with the following fault conditions: Sensor error (internal code or LED error), low voltage, over-temperature
Run LED green	LED is ON with the following conditions: Preop-, Safeop and Op-State (EtherCAT Status machine)
2 x Link LEDs yellow	LED is ON with the following conditions (Port IN and Port OUT): Link detected

Electrical connection EtherCAT with connector output 3 x M12

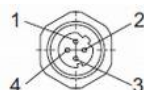
Bus Port in	Signal	Transmit data +	Receive data +	Transmit data -	Receive data -	
	Abbreviation	TxD+	RxD+	TxD-	RxD-	
	PIN	1	2	3	4	
Power supply	Signal	Voltage +	-	Voltage -	-	
	Abbreviation	+V	-	0 V	-	
	PIN	1	2	3	4	
Bus Port out	Signal	Transmit data +	Receive data +	Transmit data -	Receive data -	
	Abbreviation	TxD+	RxD+	TxD-	RxD-	
	PIN	1	2	3	4	

DESCRIPTION PROFINET

Parameters of the Profinet interface

Code	Binary
Protocol	PROFINET 10
LED Link1/Link2	two coloured: green = active link yellow = data transfer

Ezturn Software for Profinet (supplied with the encoder)

- Monitoring of cyclic data (e.g. position, speed)
- Monitoring of acyclic data (e.g. IMO, electronic name plate, encoder parameters, warnings and error messages, preset)
- Setting of preset values
- Firmware updates via the bus

Electrical connection Profinet with connector output 3 x M12

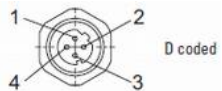
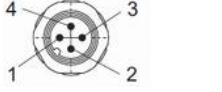
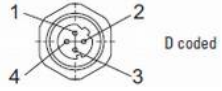
Bus Port 1	Signal	Transmit data +	Receive data +	Transmit data -	Receive data -	
	Abbreviation	TxD+	RxD+	TxD-	RxD-	
	PIN	1	2	3	4	
Power supply	Signal	Voltage +	-	Voltage -	-	
	Abbreviation	+V	-	0 V	-	
	PIN	1	2	3	4	
Bus Port 2	Signal	Transmit data +	Receive data +	Transmit data -	Receive data -	
	Abbreviation	TxD+	RxD+	TxD-	RxD-	
	PIN	1	2	3	4	

General information about PROFINET IO

The PROFINET encoder implements the Encoder Profile 4.1. (according to the specification Encoder Version 4.1 Dec 2008“).

It permits scaling and preset values, as well as many other additional parameters to be programmed via the PROFINET-Bus.

When switching on, all parameters are loaded from an EEPROM, where they were saved previously to protect them against power-failure, or taken over by the controller in the start-up phase.

Position, speed and many other states of the encoder can be transmitted.

PROFINET IO

The complete encoder profile according to Profile Encoder Version 4.1 as well as the Identification & Maintenance functionality Version 1.16 has been implemented. IM blocks 0, 1, 2, 3 and 4 are supported.

The Media Redundancy Protokoll is implemented here.

Basically, the advantage of MRP is that the functionality of the components, which are wired in a ring structure, is maintained in case of a failure or of a breakage of the wires in any location.

OPTIONS

The following table gives an overview of frequently used options, with which the standard sensors can be equipped. Please pay attention that not all options can be combined. You will find the not-combinable options on page 15 and 16 in the section of the product codes.

Option	Order code	Description
Synthetic wire rope (instead of stainless steel wire rope)	COR	Synthetic wire rope, made out of abrasion resistant and enhanced Coramid.
Protection class IP67 (instead of IP65)	IP67	Use option IP67, if the sensor will operate in a humid environment. Note that with this option there may occur a light hysteresis in the output signal due to the special sealing. The max. acceleration and displacement speed are reduced to 80 % of the specified value.
Corrosion protection	CP	Includes a V4A wire rope, stainless steel bearings and option M4. The sensors rope drum gets HARTCOAT® coated. This coating is a hard-anodic oxidation that protects the sensor from corrosion by aggressive media (e. g. sea water) with a hard ceramics-like layer.
Increased corrosion protection only in combination with analog output	ICP	Components of the housing and the rope drum get HARTCOAT® coated. Includes the options CP, IP67 and M4.
Increased temperature range Low only in combination with analog output	T40	Special components and a low temperature grease make a working temperature down to -40 °C (up to +85°C) possible.
Increased temperature range High only in combination with potentiometer 1R	T120	Sensors with potentiometer output (1R) and cable output can be operated from -20 to +120 °C when this option is used. (NOT in combination with voltage-, current- or digital output signals)
Changed rope outlet	S1, S2, S3	S1: rope outlet sideways at the top S2*: rope outlet sideways at the bottom S3*: rope outlet on the bottom * with modified mounting plate, see page 13
Changed cable or connector orientation only for digital incremental output and digital absolute output	K1, K2, K3	Standard: sideways, opposite to the rope outlet K1: at the top K2: sideways, same side as the rope outlet K3: at the bottom
Rope fixation by M4 thread	M4	Optional, pivoted rope fixation with screw thread M4, length 22 mm. Ideal for attachment to through holes or thread holes M4.
Ring eye	RI	The end of the wire rope is equipped with a ring eye instead of a rope clip. Inside diameter 20 mm
Inverted output signal only in combination with analog output	IN	The analog signal of the sensor is increasing by extracting the rope (standard). Option IN inverts the signal, i. e. the signal of the sensor declines by extracting the rope.

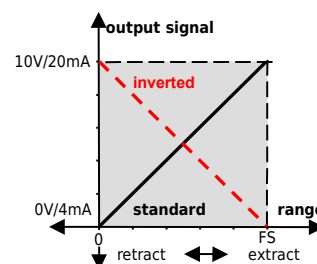
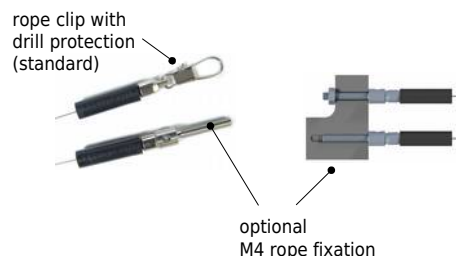
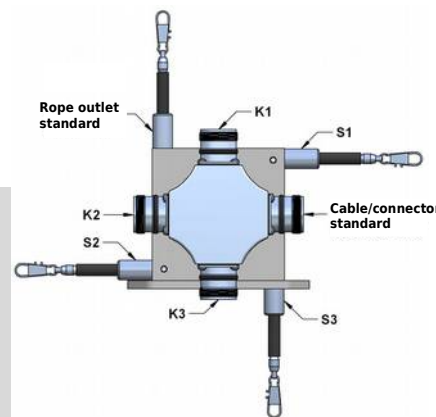

ACCESSORIES

Deflection pulley - UR2

The rope must be extracted from the sensor **vertically**. The maximum variation from the vertical is 3°. A deflection pulley allows a change in the direction of the wire rope. Several pulleys may be used. The rope clip must not be guided over the deflection pulley.

material: anodised aluminium, POM

mounting: by 2 hexagon socket or countersunk screws M6,
vertical or horizontal mounting possible.

Ball bearings: with special low temperature grease and RS-sealing.

Temperature: -40...+80 °C.

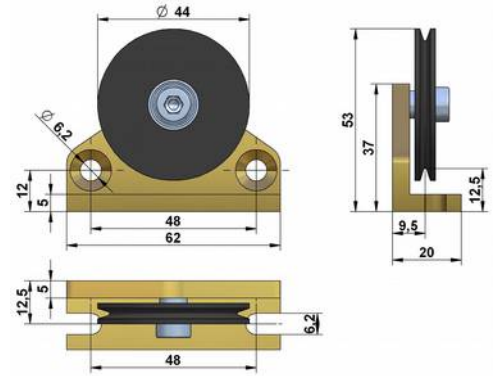
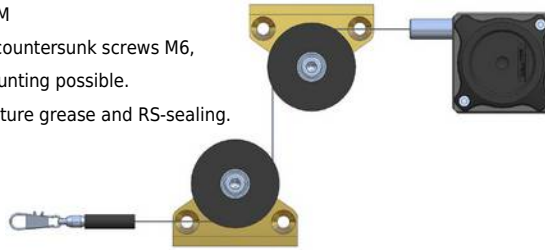

Rope extension - SV

For bridging a greater distance between the measuring target and the sensor a rope extension can be applied. The rope clip must not be guided over the deflection pulley.

Please specify the length needed in your order (XXXX). The minimum length is 150 mm:

SV1-XXXX: rope extension (150...4995 mm)

SV2-XXXX: rope extension (5000...19995 mm)

SV3-XXXX: rope extension (20000...40000 mm)

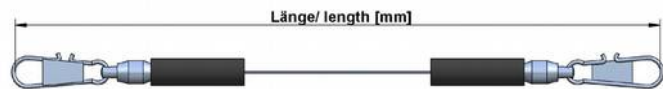

Magnetic clamp - MGG1

Use the magnetic clamp to quickly attach the rope to metallic objects without any assembly time. A rubber coating provides gentle contact (e. g. on varnished surfaces) and prevents from slipping due to vibration. The magnet consists of a neodym core for an increased adhesive force of 260 N. The hook makes it easy to attach the rope clip.

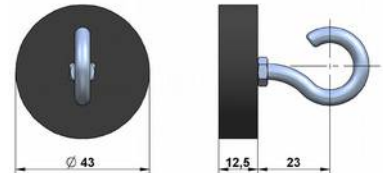

ACCESSORIES ANALOG OUTPUT

Cable with connector M12, 4 poles, shielded

K4P2M-S-M12 2 m, connector straight

K4P5M-S-M12 5 m, connector straight

K4P10M-S-M12 10 m, connector straight

K4P2M-SW-M12 2 m, connector angular

K4P5M-SW-M12 5 m, connector angular

K4P10M-SW-M12 10 m, connector angular

PIN No.	cable colour	PIN No.	cable colour
Pin 1	brown	Pin 3	blue
Pin 2	white	Pin 4	black



Mating Connector M12, 4 poles, shielded

D4-G-M12-S straight, M12 for self assembly

D4-W-M12-S angular, M12 for self assembly

protection class: IP67

temperature: -25...+90 °C

cable passage: \varnothing 4...8 mm

wire cross-section: 0.14...0.34 mm²

mode of connection: spring cage

Digital display - PAXD (for Potentiometer)

Use the PAXD display to visualise the measured distance of the position transducer with a potentiometer as sensor element. A transmission of the measurement data to a computer or PLC can be done with interface plug-in cards.

Inputs: Potentiometer signal

Analog output (plug-in cards): 0...20 mA, 4...20 mA, 0...10 V

Serial interfaces (plug-in cards): RS485, RS232, DeviceNet, USB, Profibus, Relay output, Transistor output

Protection class: IP65 (Front panel)

Display: 5 digits

PAXD000B: 1 channel, power supply: 85 to 250 VAC

PAXD001B: 1 channel, power supply: 11 to 36 VDC/24 VAC



For further information please see the data sheet of the PAXD display series

ACCESSORIES ANALOG OUTPUT

Digital displays PAXP (1 channel) and PAXDP (2 channels) for sensors with analog output signals 0..10V or 4..20 mA

Use the PAXD or PAXDP display to visualise the measured distance of transducers with an analog output signal. A transmission of the measurement data to a computer or PLC can be done with interface plug-in cards.

Inputs:	0...10 V or 4...20 mA, 2 independent counters (for PAXDP)
Analog output (plug-in cards):	0...20 mA, 4...20 mA, 0...10 V
Serial interfaces (plug-in cards):	RS485, RS232, DeviceNet, USB, Profibus, Relay output, Transistor output
Protection class:	IP65 (front panel)
Display:	5 digits

PAXP000B:	1 channel, power supply: 85 to 250 VAC
PAXP001B:	1 channel, power supply: 11 to 36 VDC/24 VAC
PAXDP000B:	2 channels, power supply: 85 to 250 VAC
PAXDP001B:	2 channels, power supply: 11 to 36 VDC/24 VACC

For further information please see the PAXD and PAXDP data sheet.



ACCESSORIES DIGITAL OUTPUT INCREMENTAL

Cable with connector M12, 8 poles, shielded

K8P2M-S-M12	2 m, connector straight
K8P5M-S-M12	5 m, connector straight
K8P10M-S-M12	10 m, connector straight
K8P2M-SW-M12	2 m, connector angular
K8P5M-SW-M12	5 m, connector angular
K8P10M-SW-M12	10 m, connector angular

Mating connector M12, 8 poles, shielded

D8-G-M12-S	mating connector straight
D8-W-M12-S	mating connector angular
	protection class: IP67
	temperature: -25...+90 °C
	cable passage: \varnothing 4...8 mm
	wire diameter: 0.14...0.34 mm ²

Mating connector M23, 12 poles

CON012-S	straight, metal housing
	wire diameter: AWG 16...26 mm ²
	cable diameter: \varnothing 5.5...10 mm

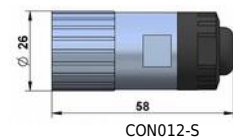

Digital distance and speed display - WAY-D for incremental output signals

Use the WAY-D display to visualise the measured distance or the speed (tachometer) of the position transducer. A transfer of data to a PC or PLC can be done with the RS232 interface of the WAY-DR.

Protection class:	IP65 (front panel)
Display:	6 digits
Supply:	115 / 250 VAC

Output Linedriver L (TTL, RS422):

WAY-DS-5VH:	display only, input level TTL
WAY-DG-5VH:	display with two presets and switching outputs, input level TTL
WAY-DR-5VH:	display with serial interface RS232 / RS485, input level TTL

Output Push-Pull G:

WAY-DS:	display only, input level HTL
WAY-DG:	display with two presets and switching outputs, input level HTL
WAY-DR:	display with serial interface RS232 / RS485, input level HTL

For further information please see the WAY-D data sheet.



ACCESSORIES DIGITAL OUTPUT ABSOLUTE SSI

Digital distance and speed display - WAY-SSI for SSI output signals

Use the WAY-SSI display to visualise the measured distance or the speed (tachometer) of the position transducer. A transfer of data to a PC or PLC can be done with the RS232 interface of the WAY-SSI-R.

Protection class:	IP65 (front panel)
Display:	6 digits
Supply:	115 / 250 VAC
WAY-SSI-S:	display only
WAY-SSI-A:	display with analog output
WAY-SSI-G:	display with two presets and switching outputs
WAY-SSI-R:	display with serial interface RS232 / RS485

For further information please see the WAY-SSI data sheet.



MECHANICAL DATA

Measurement Range [mm]	Extraction Force F_{min} [N]	Extraction Force F_{max} [N]	Speed V_{max} [m/s] *	Acceleration a_{max} [m/s ²] *
3125	8.0	10.0	10	140
4000	8.0	11.0	10	140
5000	8.0	11.6	10	140

* reduced to 80 % when option IP67 is used

INSTALLATION

- Mount the sensor at the designated place by using the fixing holes before extracting the rope and before attaching the rope to the measuring target.
- Open the rope clip after the sensor is fully mounted and extract the measuring rope. Hook the rope clip on the measuring object and close the bracket of the clip. For safety reasons put a screw driver trough the clip to extract the rope.
- Check the track of the measuring target on collision with the sensor housing and on exceeding the specified measurement range. When installing the sensor make sure that the rubber stopper does not touch the rope outlet.
- Connect the electronics according to the sensor type. When laying the cables be careful not to under-run the minimal allowed bending radius of the cable (5 x cable diameter).
- **The rope must be extracted from the sensor vertically.** The maximum variation from the vertical is 3°. Avoid carefully extracting the rope at an inclination, since the durability of the instrument would shorten considerably. If it is not possible to keep the limit of 3°, a deflection pulley has to be used.
- The measuring range begins after approximately 2 mm extracted rope (=zero point). The mechanical reserve at the end of the measuring range is about 20 mm.
- When mounting outdoors protect the sensor and the rope from icing at temperatures below 0 °C.
- Guide the rope preferably in corners or guarded in channels to prevent pollution or accidental touch.
- When operating the sensor, take care **not to let the rope snap back** by mistake or extract the rope **over the specified measurement range**, as this might destroy the sensor.
- Maintenance: These instruments are maintenance-free. If however, the rope is soiled due to adverse environmental conditions, it can be cleaned with a cloth drenched in resin-free machine oil.



Mounting: standard rope outlet, rope outlet sideways top (S1)

The sensor is usually installed by using the regular mounting plate (see technical drawing on page 4).

By disassembling the mounting plate, there are 2 x M4 threads in the sensor housing for alternative installation.

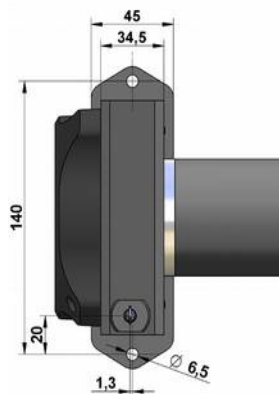

Mounting: rope outlet sideways bottom (S2), rope outlet bottom (S3)

Sensors with option rope outlet S2 and S3 have a modified base plate.

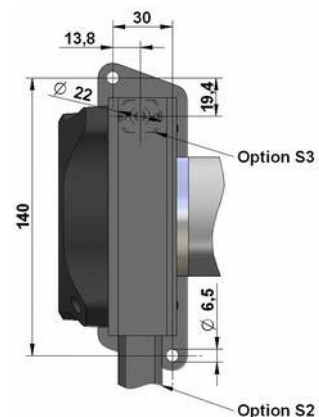

ORDER CODE ANALOG OUTPUT

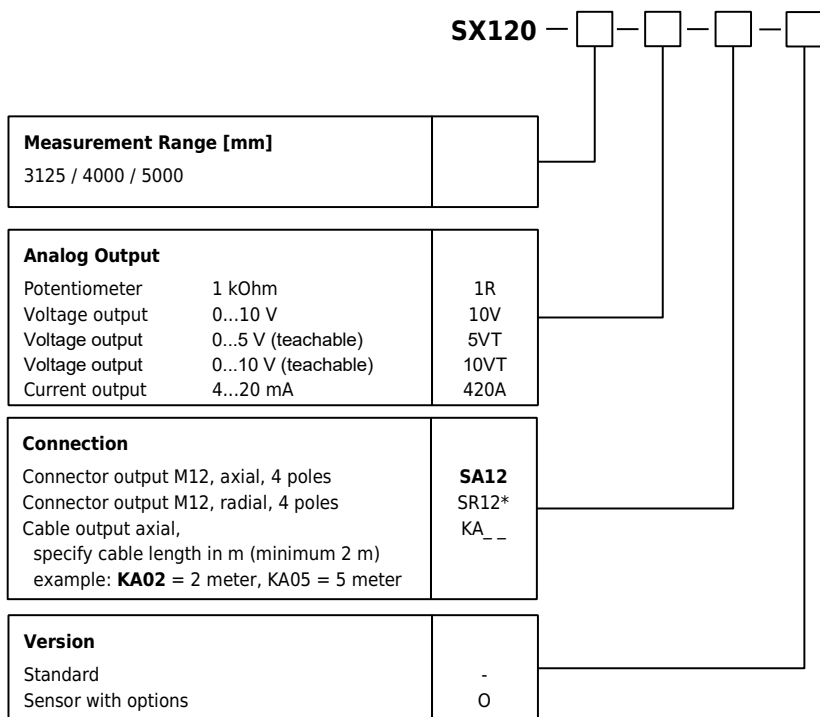

Option	Description
M4	rope fixation M4 thread
COR	synthetic wire rope, made out of Coramid
RI	ring eye (instead of rope clip)
S1	rope outlet sideways top
S2	rope outlet sideways bottom
S3	rope outlet bottom
IN	inverted output signal
L05	improved linearity 0.05 %
T40	increased temperature range low -40...+85°C
T120	increased temperature range high -20...+120 °C
IP67	protection class IP67
CP	corrosion protection SX120
ICP	increased corrosion protection SX120

Option	not combinable with
M4	CP, ICP
RI	CP, ICP
T40	L05
T120	IP67, COR, CP, ICP, 10V, 420A, SA12, SR12
IP67	TEMP120, ICP
CP	M4, RI
ICP	IP67, M4, RI

Bold text: standard with shorter lead time

ORDER CODE DIGITAL OUTPUT INCREMENTAL

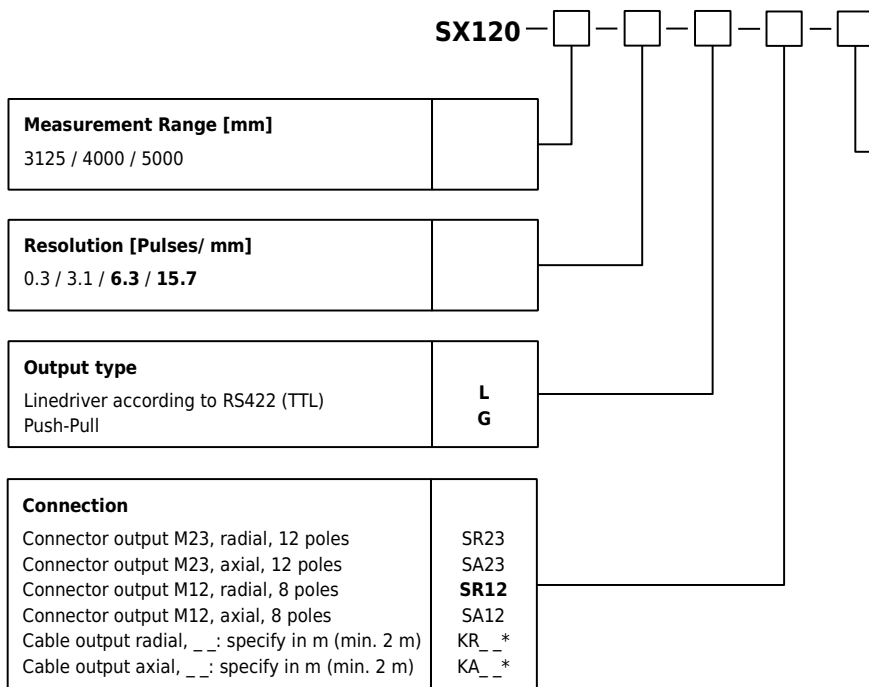

Version	Description
-	Standard
O	Sensor with options

Option	Description
M4	rope fixation M4 thread
COR	synthetic wire rope, made out of Coramid
RI	ring eye (instead of rope clip)
S1	rope outlet sideways top
S2	rope outlet sideways bottom
S3	rope outlet bottom
K1	cable/connector orientation top
K2	cable/connector orientation left
K3	cable/connector orientation bottom
L02	improved linearity 0.02 %
IP67	protection class IP67
CP	corrosion protection SX120

Option	not combinable with
M4	CP
RI	CP
L02	resolutions 0.3 / 3.1
CP	M4, RI

* for linedriver: 10 wires (with additional sensor lines)
for push-pull: 8 wires (without sensor lines)

Bold text: standard with shorter lead time

ORDER CODE DIGITAL OUTPUT ABSOLUTE

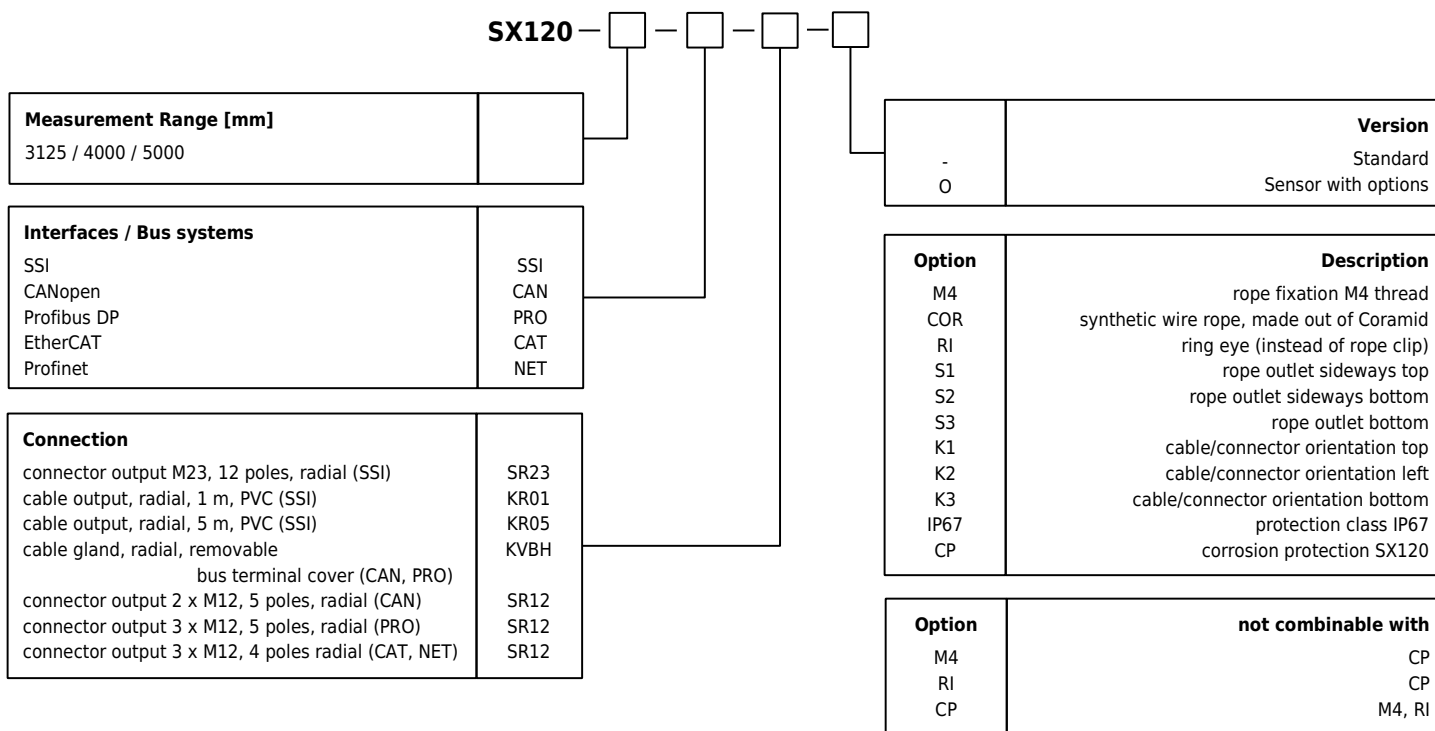

GENERAL ACCESSORIES

UR2	Deflection pulley
MGG1	Magnetic clamp
SQUEEZER1000	1 m cable, open ends
SQUEEZER2000	2 m cable, open ends

SV1-XXXX	rope extension (150...4995 mm)
SV2-XXXX	rope extension (5000...19995 mm)
SV3-XXXX	rope extension (20000...40000 mm)

ACCESSORIES ANALOG OUTPUT

Cable with mating connector M12, 4 poles, shielded

K4P2M-S-M12	2 m, straight connector
K4P5M-S-M12	5 m, straight connector
K4P10M-S-M12	10 m, straight connector
K4P2M-SW-M12	2 m, angular connector
K4P5M-SW-M12	5 m, angular connector
K4P10M-SW-M12	10 m, angular connector

Mating Connector M12, 4 poles, shielded

D4-G-M12-S	straight, M12 for self assembly
D4-W-M12-S	angular, M12 for self assembly

Digital display 1 channel, 0...10V/4...20 mA

PAXP000B	1 channel, supply: 85 to 250 VAC
PAXP001B	1 channel, supply: 11...36 VDC/24 VAC

Digital display 2 channels, 0...10V/4...20 mA

PAXDP00B	2 channels, supply: 85 to 250 VAC
PAXDP01B	2 channels, supply: 11...36 VDC/24 VAC

Digital display 1 channel, Potentiometer

PAXD000B	1 channel, supply: 85 to 250 VAC
PAXD001B	1 channel, supply: 11...36 VDC/24 VAC

ACCESSORIES DIGITAL OUTPUT INCREMENTAL

Cable with mating connector M12, 8 poles, shielded

K8P2M-S-M12	2 m, straight connector
K8P5M-S-M12	5 m, straight connector
K8P10M-S-M12	10 m, straight connector
K8P2M-SW-M12	2 m, angular connector
K8P5M-SW-M12	5 m, angular connector
K8P10M-SW-M12	10 m, angular connector

Cable with mating connector M23, 12 poles, shielded

K8P2M-S-M23	2 m, straight connector
K8P5M-S-M23	5 m, straight connector
K8P10M-S-M23	10 m, straight connector

Mating Connector M23, 12 poles, shielded

CON012-S	straight, M23 for self assembly, metal housing
----------	--

Mating Connector M12, 8 poles, shielded

D8-G-M12-S	straight, M12 for self assembly
D8-W-M12-S	angular, M12 for self assembly

Digital display 1 channel, Linedriver L (input level TTL, RS422)

WAY-DS-5VH	display only
WAY-DG-5VH	display with two presets and switching outputs
WAY-DR-5VH	display with serial interface RS232 / RS485

Digital display 1 channel, Push-Pull G

WAY-DS	display only
WAY-DG	display with two presets and switching outputs
WAY-DR	display with serial interface RS232 / RS485

ACCESSORIES DIGITAL OUTPUT ABSOLUTE

SSI output:

K12P02M-S-M23-SSI	2 m cable, shielded, M23 connector straight
K12P05M-S-M23-SSI	5 m cable, shielded, M23 connector straight
K12P10M-S-M23-SSI	10 m cable, shielded, M23 connector straight
K12P15M-S-M23-SSI	15 m cable, shielded, M23 connector straight
CON012-S	Mating connector M23 shielded, straight, 12 poles

Digital display 1 channel, for sensors with SSI signal

WAY-SSI-S	display only
WAY-SSI-A	display with analog output
WAY-SSI-G	display with two presets and switching outputs
WAY-SSI-R	display with serial interface RS232 / RS485

Profibus DP:

K5P2M-B-M12-PROF	2 m cable, plug female M12, 5 poles, open ends
K5P2M-SB-M12-PROF	2 m cable, connector male M12, 5 poles, plug female M12
K5P2M-S-M12-PROF	2 m cable, connector male, M12, 5 poles, open ends
M12-PROF-AW	terminator

CANopen output:

K5P2M-B-M12-CAN	2 m cable, plug female M12, 5 poles, open ends
K5P2M-SB-M12-CAN	2 m cable, connector male M12, 5 poles, plug female M12
K5P2M-S-M12-CAN	2 m cable, connector male, M12, 5 poles, open ends

EtherCAT / Profinet:

K4P2M-S-M12-CAT	2 m cable, connector male M12, 4 poles, open ends
K4P5M-S-M12-CAT	5 m cable, connector male M12, 4 poles, open ends
K4P10M-S-M12-CAT	10 m cable, connector male M12, 4 poles, open ends
K4P2M-SS-M12-CAT	2 m cable, connector male M12 on both ends, 4 poles
K4P5M-SS-M12-CAT	5 m cable, connector male M12 on both ends, 4 poles
K4P10M-SS-M12-CAT	10 m cable, connector male M12 on both ends, 4 poles

Subject to change without prior notice.

WayCon Positionsmesstechnik GmbH

email: info@waycon.de
internet: www.waycon.de

Head Office

Mehlbeerenstr. 4
82024 Taufkirchen
Tel. +49 (0)89 67 97 13-0
Fax +49 (0)89 67 97 13-250

Office Köln

Auf der Pehle 1
50321 Brühl
Tel. +49 (0)2232 56 79 44
Fax +49 (0)2232 56 79 45