

THE RS425 NON-CONTACT TORQUE TRANSDUCER



Bearing-less Torque Sensor with completely separate rotor and stator

The Datum Electronics Series RS425 non-contact rotary torque transducers have been designed to fit easily in line with any drivetrain or test bed using either a spline or keyway shaft.

We are able to modify the ends of the transducer to best suit your requirements, and can even design bespoke ends to fit. This type of transducer has many advantages over other torque systems including: zero bearing friction, high speed and high torque applications.

RS425 System Performance and Benefits:

Lightweight Torque transducer with completely separate rotor and stator set

No mechanical friction, long-term operation reduced maintenance

Ideal keyway shaft for easy fitting to test rigs and drive systems

Spline shafts are also available as an alternative to a keyway shaft

No bearings – ideal for high speed applications

Standard RS425 torque transducer range available from 0-10Nm to 0-30,000Nm

Analogue Output available & compatible with LABVIEW software

Ideal for fully sealed or underwater applications (IP 68) system upgrade

The RS425 Torque Sensor Range

The RS425 torque transducer utilises a strain gauged shaft for accurate and reliable torque measurement and a set of rotating on shaft conditioning electronics, the digital signals are transmitted to the non-rotating part of the system or stator providing a reliable and highly accurate torque measurement solution. The rotor is continuously powered enabling static torque measurement to be made. Not only does the RS425 Series offer great technical advantages but the range of torque sensors are competitively priced.

The RS425 series torque transducer is not limited by bearings; therefore it can be used at higher speeds, and places no bearings loads on to the shaft. The stator needs to be mounted in relation to the shaft within an operating envelope of +/- 3 to 5mm. The standard range can measure torque ranges from 0-10Nm up to 30kNm, the same modular elements have been applied to bespoke torque transducers for use down as low as 3Nm and up to 500kNm and above.

Using our new generation of electronics as found in our industry standard M425 Torque transducer, the RS425 gives customers the ability to choose the sample rate that they need from 1 up to 4000sps, with higher resolution using up to 24bit technology.

In many cases higher RPM ratings can be attained - please call our engineering team to discuss you applications

The Competitive Edge

The Series RS425 transmits calibrated digital data as this is a cleaner and more defined method of transmitting data. The on-shaft signal from the strain gauge is converted to a digital signal and amplified on shaft. It is this signal that is taken off the shaft and processed by either with our DUI; Datum Universal Interface, or with our free of charge GUI software, providing the end user with clean and definitive data transmission.

RS425 Analogue Options

If an analogue signal is required, our Series 425 torque transducers are able to provide either 4-20mA or 0-10VDC output with our DUI; by converting the digital data signal from the torque transducer to an analogue signal. However, the effect of external or electrical noise can impact upon signal strength and definition in this instance. Other commercial applications may use slip rings or analogue signals to transmit data, but the Datum Electronics series 425 outputs digital as standard.

If your requirements dictate anything above our standard torque sensor range of 30,000Nm we can and have engineered torque measurement transducers up to 500,000Nm for the RS425. Please discuss your requirements with our sales team.

Instrumentation

The Series RS425 transducer is compatible with our new DUI; Datum Universal interface which gives a range of digital and analogue outputs as well as a digital display of the torque speed and power. It can also be set in a legacy mode to work with our older range of indicators and displays

A popular option is to view data from the transducer on a PC or laptop for torque data analysis. Our GUI software has been developed to allow the user to view the torque data in real time with optional data analysis for performance monitoring and control. Using a simple USB interface, or Ethernet connection the transducer data can be displayed and logged at the touch of a button with our GUI.

RS425 Performance Information

RS425 SERIES	Size 1	Size 2	Size 3	Size 4	Size 5
Torque range	0-100Nm	0-500Nm	0-2,000Nm	0-10,000Nm	0-30,000Nm
Accuracy class	0.1%FSD	0.1%FSD	0.1%FSD	0.1%FSD	0.1%FSD
Mechanical connection	Keyway or Spline Shaft				
Signal outputs	RS485 as standard				
Optional outputs with DUI	DIGITAL: USB, Ethernet, RS485/232 and USB memory logging. ANALOGUE: 3 Channels of Torque, Speed and Power as 0-10V/4-20mA.				
Transmission	Strain gauge signal, digital on-shaft with inductive loop				
Standard speed (rpm)	10,000rpm	10,000rpm	6,000rpm	5,000rpm	2,000rpm
Max speed (rpm)	30,000rpm	20,000rpm	16,000rpm	10,000rpm	5,000rpm
Output data	1-4000sps				

RS425 System Advantages

Accurate On Shaft Torque Measurement

Flexible shaft fittings (Spline or keyway shaft)

Modular System Assembly

Non-contact Signal Transmission

Proven Technology

Low Maintenance

Simple Linear Calibration

Engineered to fit most drive components

Rotary and Static Torque Measurement

Optional Analogue Data Output

LABVIEW compatible



RS425 Specifications

RS425 Model Size	Rated load (Nm)	Rated load (lb ft)	Standard Rotational speed (RPM)*	*Stator mass (Kgs)	Rotor mass (Kgs)	A Shaft length to face (mm)	B Body width (mm)	C Shaft Ø g6 TOL (ISO 286-2)	D Keyway length (BS 4235-1 : 1972)	E Keyway width (BS 4235-1 : 1972)	F Output module length (mm)	G Output module height (mm)	H Keyway depth off axial centre (BS 4235-1 : 1972)	I Base to shaft axial centre (mm)	J Overall height (mm)	K Base length (mm)	L Base fixing holes Centre to centre (mm)	M Fixing holes (DIN 933)
Size 1 - A	0-10	7.4	10,000	1.057	0.401	150	50	15	22.5	5	112	8.5	4.3	80	140	120	100	M8
Size 1 - B	0-20	14.8	10,000	1.057	0.421	150	50	15	22.5	5	112	8.5	4.3	80	140	120	100	M8
Size 1 - C	0-50	36.9	10,000	1.057	0.462	150	50	15	22.5	5	112	8.5	4.3	80	140	120	100	M8
Size 1 - D	0-100	73.8	10,000	1.057	0.560	150	50	15	22.5	5	112	8.5	4.3	80	140	120	100	M8
Size 2 - A	0-250	184	10,000	1.057	1.201	170	50	30	44	8	112	8.5	11	80	140	120	100	M8
Size 2 - B	0-500	369	10,000	1.057	1.276	170	50	30	44	8	112	8.5	11	80	140	120	100	M8
Size 3 - A	0-1000	738	6,000	1.057	1.688	240	50	50	78.5	12	112	8.5	20	80	140	120	100	M8
Size 3 - B	0-2000	1,475.1	6,000	1.057	2.149	240	50	50	78.5	12	112	8.5	20	80	140	120	100	M8
Size 4 - A	0-5000	3,687.9	5,000	1.152	6.112	240	50	75	78.5	20	112	8.5	30	80	140	120	100	M8
Size 4 - B	0-10,000	7,375.7	5,000	1.152	12.162	240	50	75	78.5	20	112	8.5	30	80	140	120	100	M8
Size 5 - A	0-15,000	11,064	2,000	2.138	20.499	292	60	110	116	32	112	8.5	44	120	220	200	180	M10
Size 5 - B	0-20,000	14,751	2,000	2.138	22.318	292	60	110	116	32	112	8.5	44	120	220	200	180	M10
Size 5 - C	0-25,000	18,439	2,000	2.138	34.608	292	60	110	116	32	112	8.5	44	120	220	200	180	M10
Size 5 - D	0-30,000	22,127	2,000	2.138	40.969	292	60	110	116	32	112	8.5	44	120	220	200	180	M10

Alphabet key for RS425

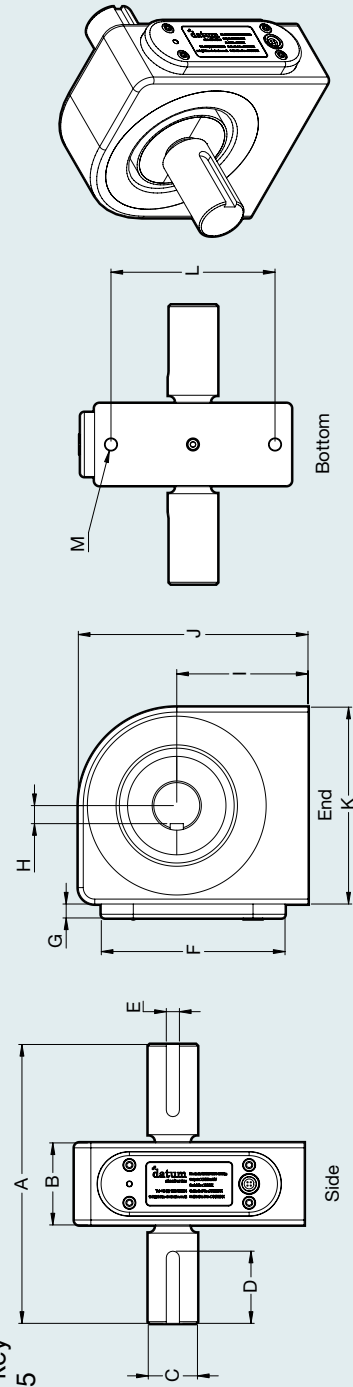

*For higher speed requirements please discuss your requirements with our sales team
This drawing and its associated design is the property of Datum Electronics Ltd. and may not be copied or used for any purpose other than that for which it is supplied, without the express written authority from Datum Electronics Ltd.



DATUM ELECTRONICS LIMITED
TELEPHONE: +44 (0) 1983 28 28 34
FAX: +44 (0) 1983 28 28 35
EMAIL: support@datum-electronics.co.uk
WEB: www.datum-electronics.co.uk

DESIGNED BY WWW.PEPPERCREATIVE.CO.UK